

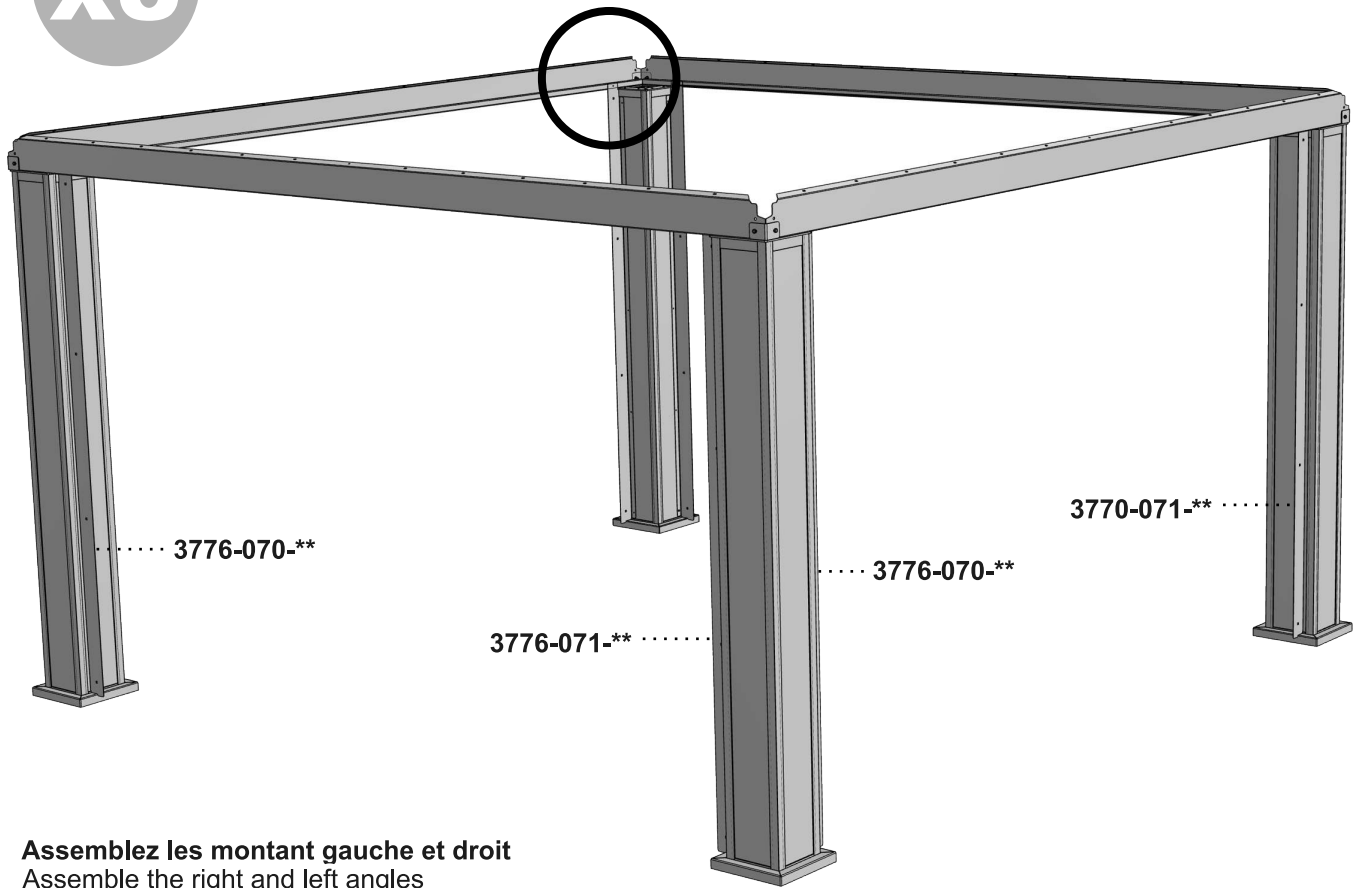

STEP
Étape 1
x8

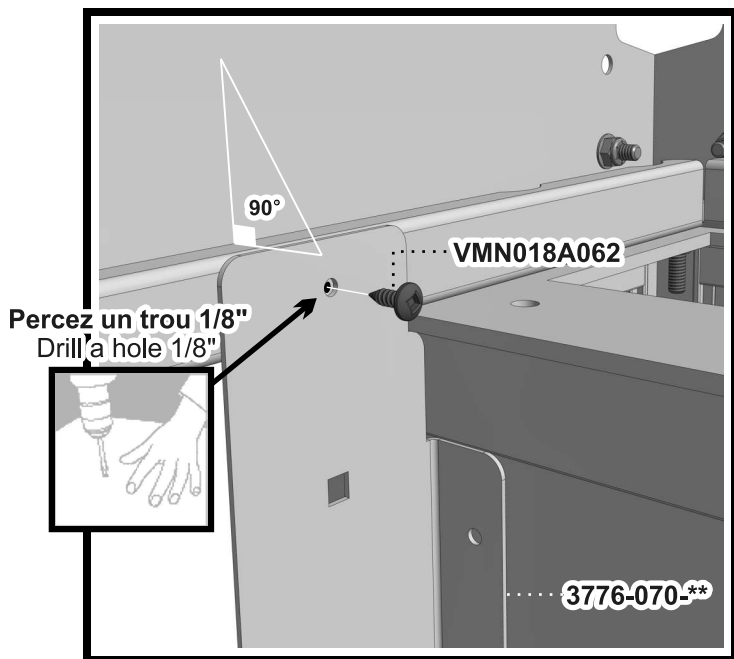

Assemblez les montant gauche et droit
Assemble the right and left angles



*Vue de l'intérieure - View from inside

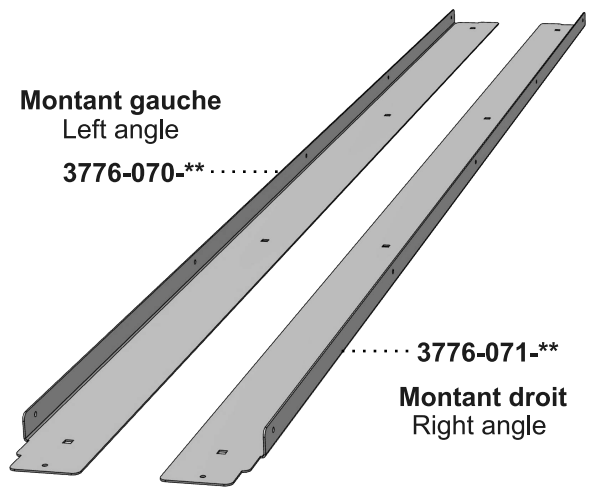

** Code couleur - Color code

STEP
Étape 2
x8

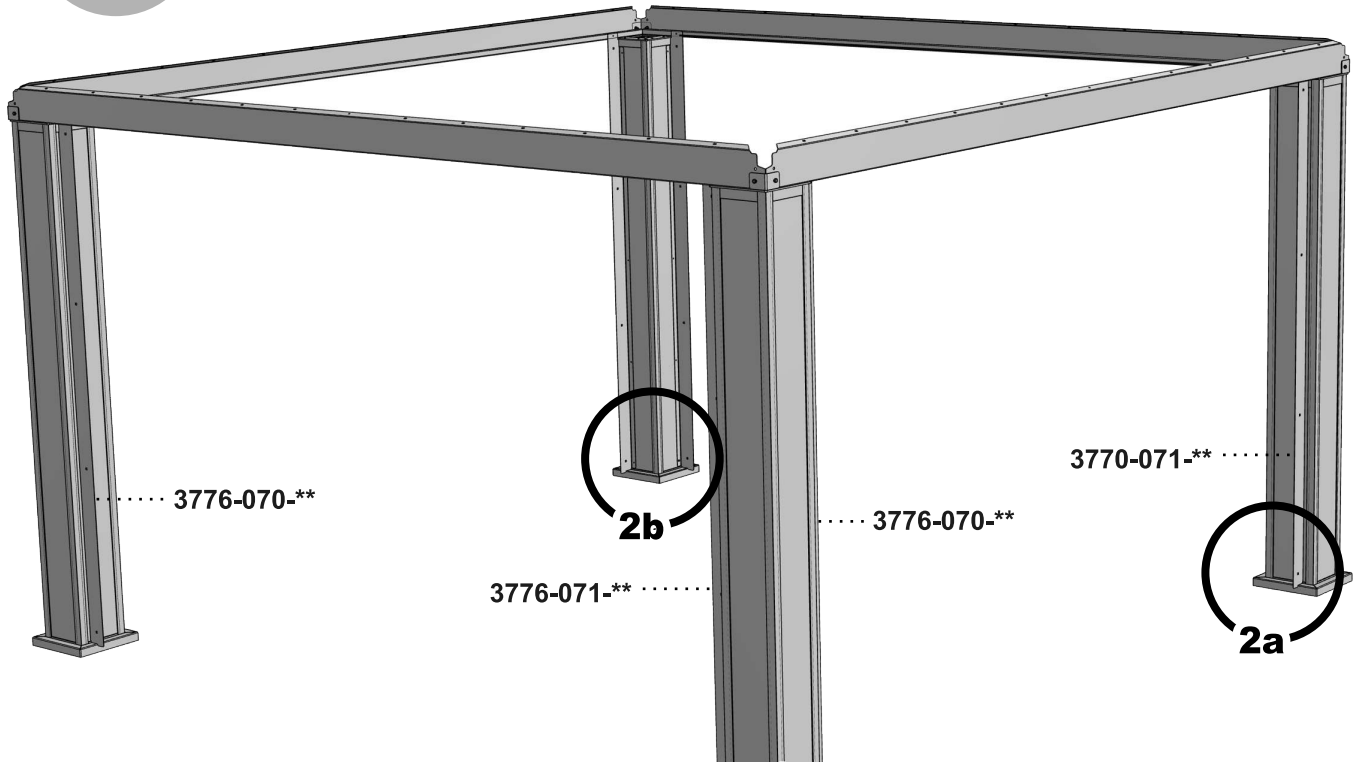

Positionnez les montants à 1 3/4"
 Position the angles at 1 3/4"

Vissez les montants sur les poteaux
 Screw the side angles on the poles

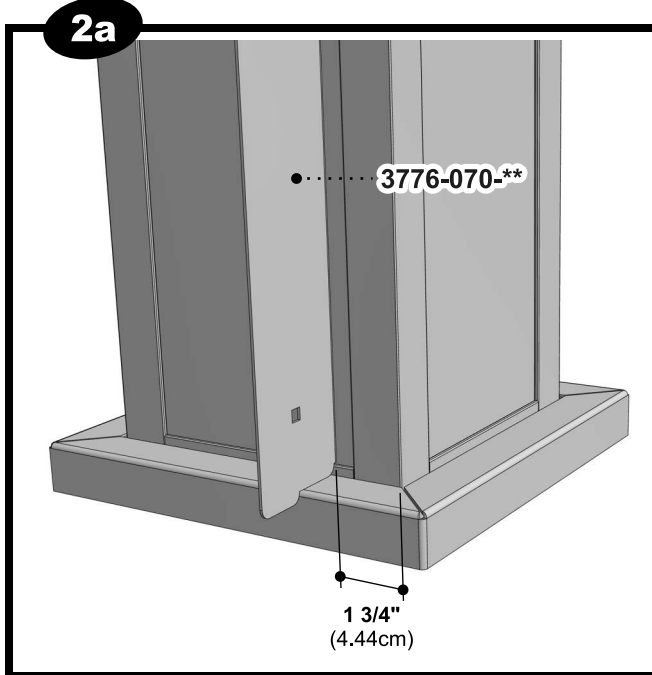

*Vue de l'extérieure - View from outside

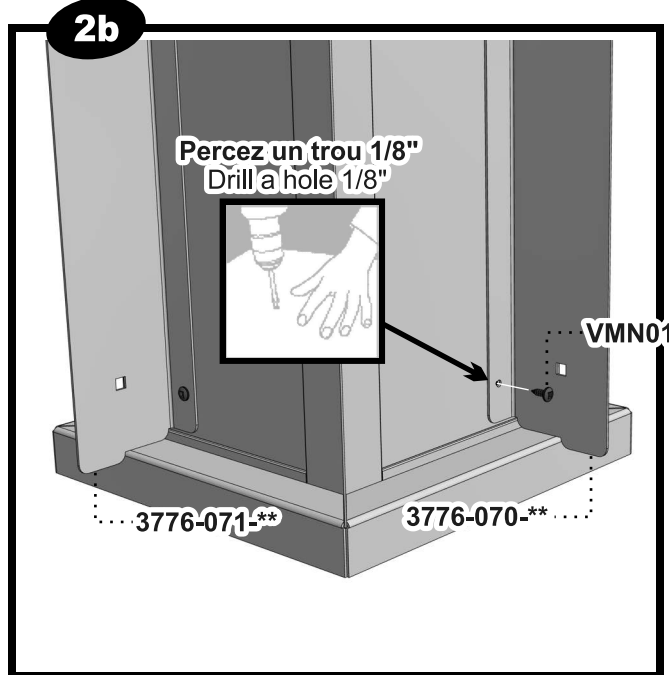

*Vue de l'intérieure - View from inside

** Code couleur - Color code

STEP
Étape 3

x4

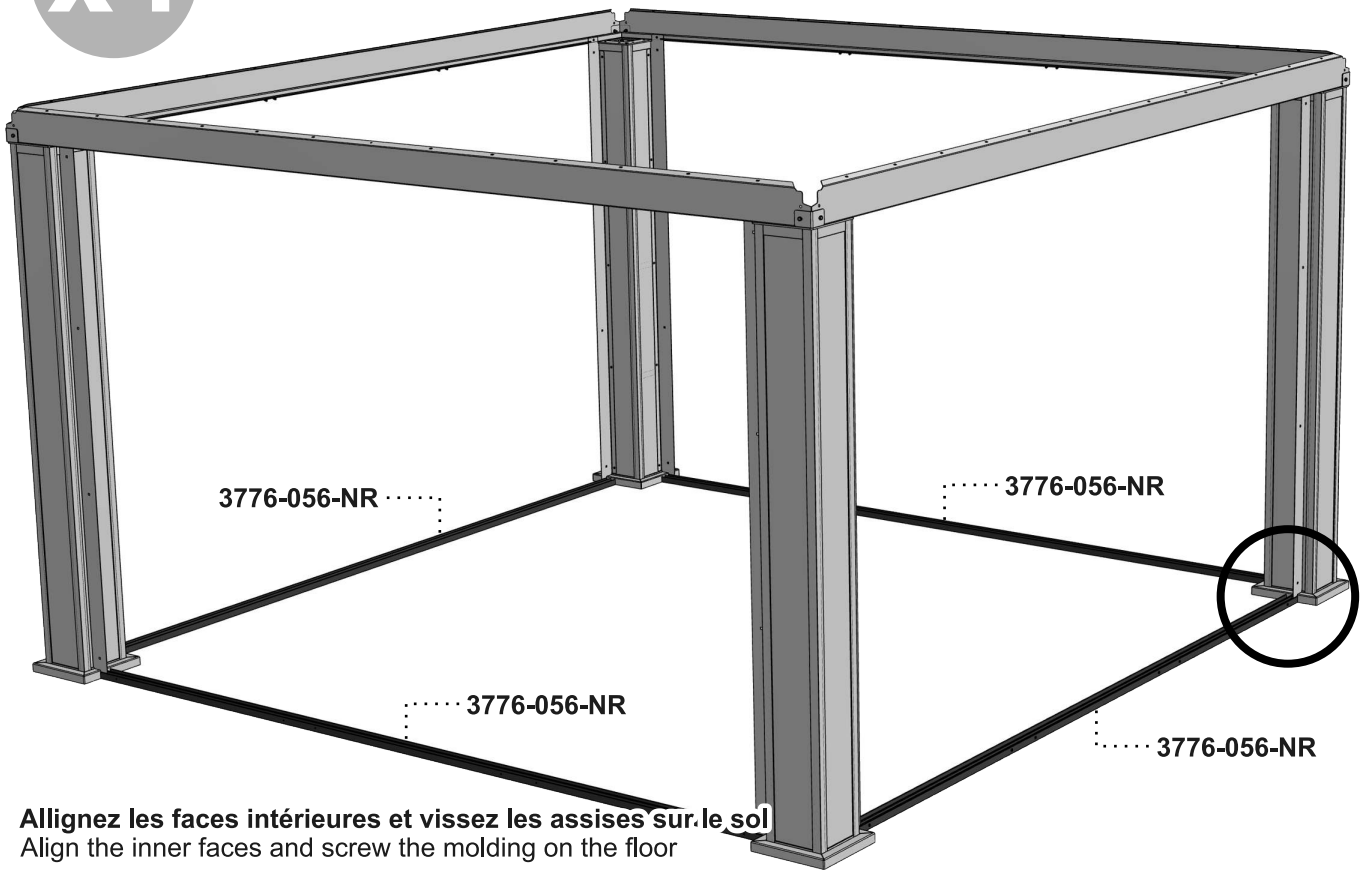

Allignez les faces intérieures et vissez les assises sur le sol
Align the inner faces and screw the molding on the floor

3

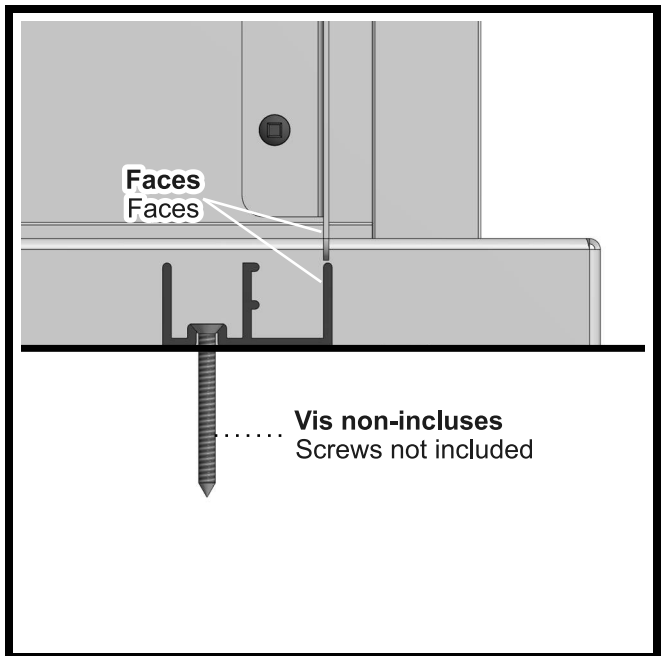
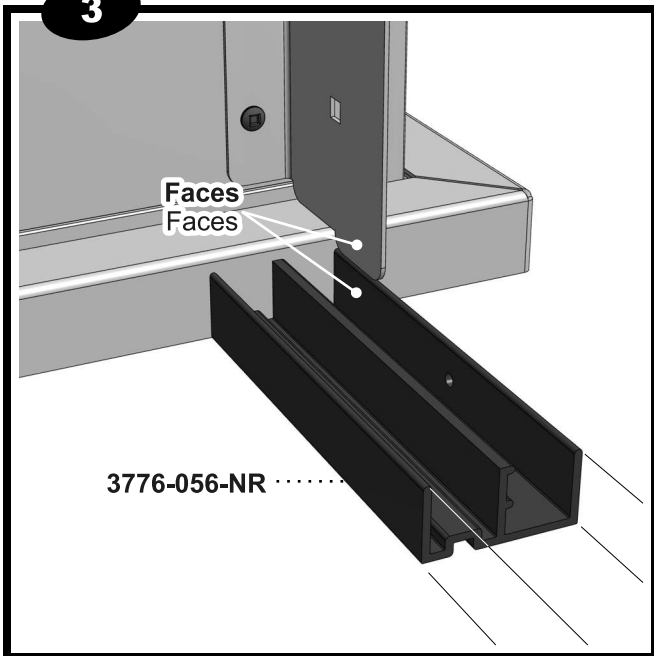

*Vue de l'intérieure - View from inside

** Code couleur - Color code

STEP
Étape 4

x4

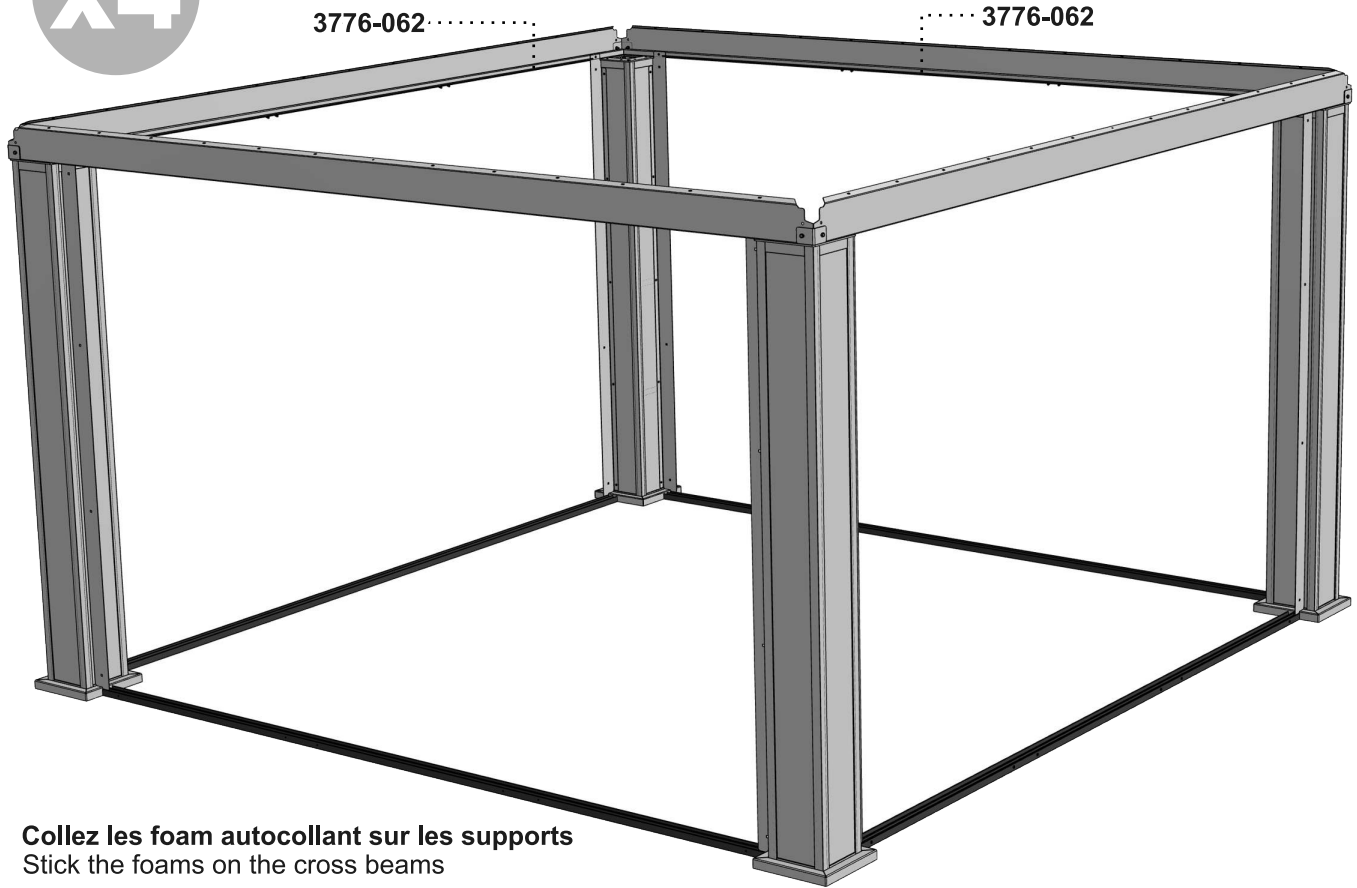

Collez les foam autocollant sur les supports
Stick the foams on the cross beams

4

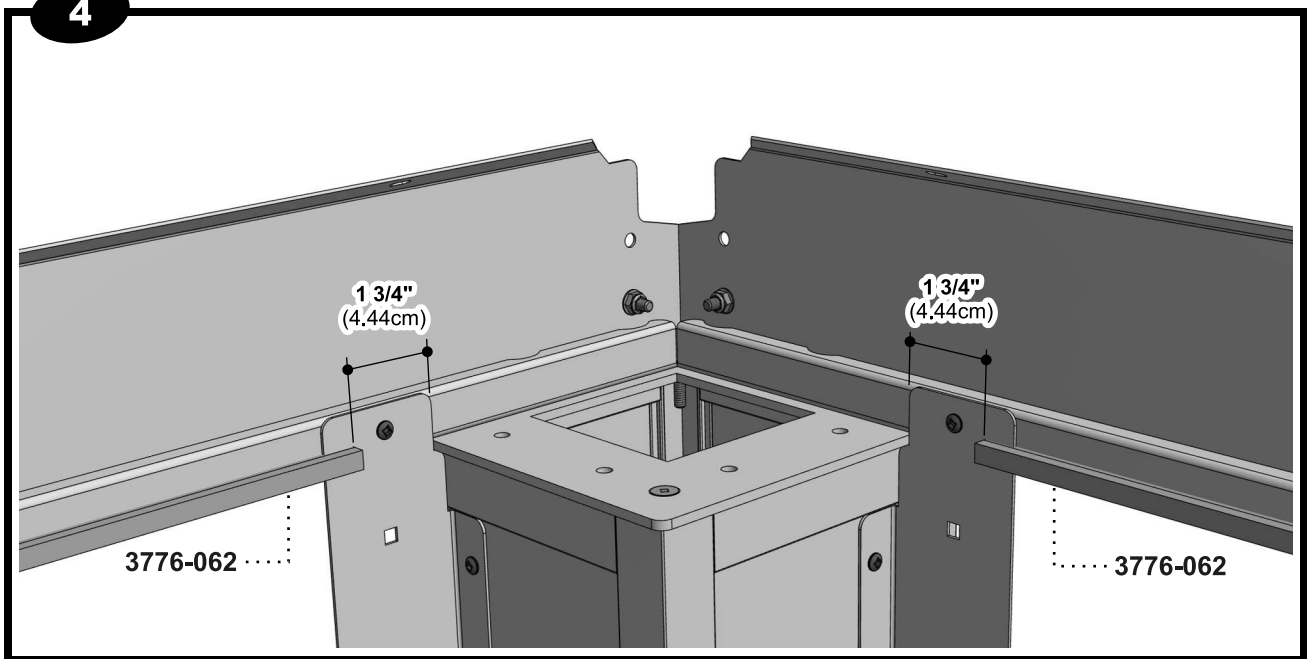

*Vue de l'intérieure - View from inside

** Code couleur - Color code

STEP
Étape 5
x1

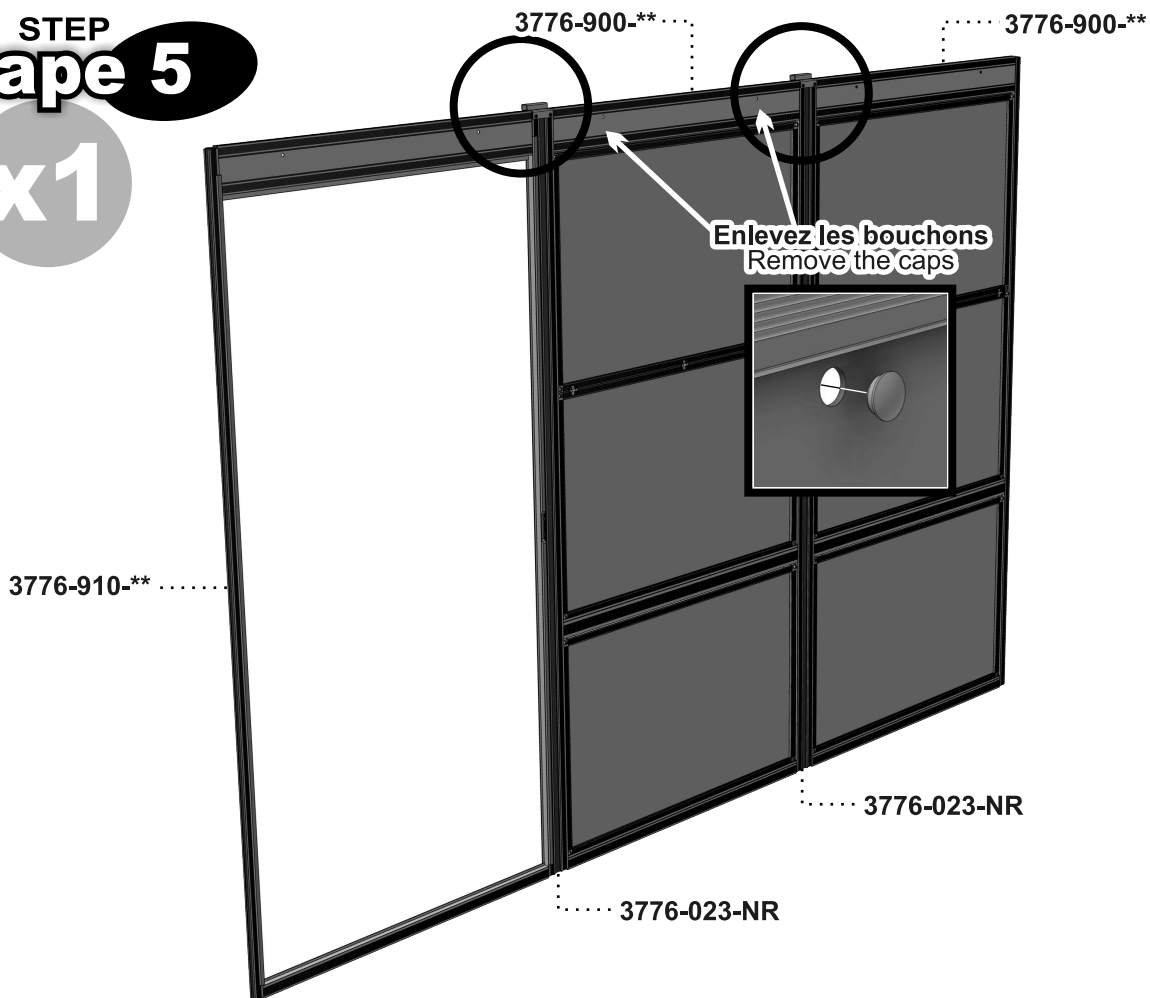

Assemblez les sections moustiquaire et positionnez le cadrage de porte à l'endroit désiré.
Assemble the screen sections and positioned the door frame at the desired location.

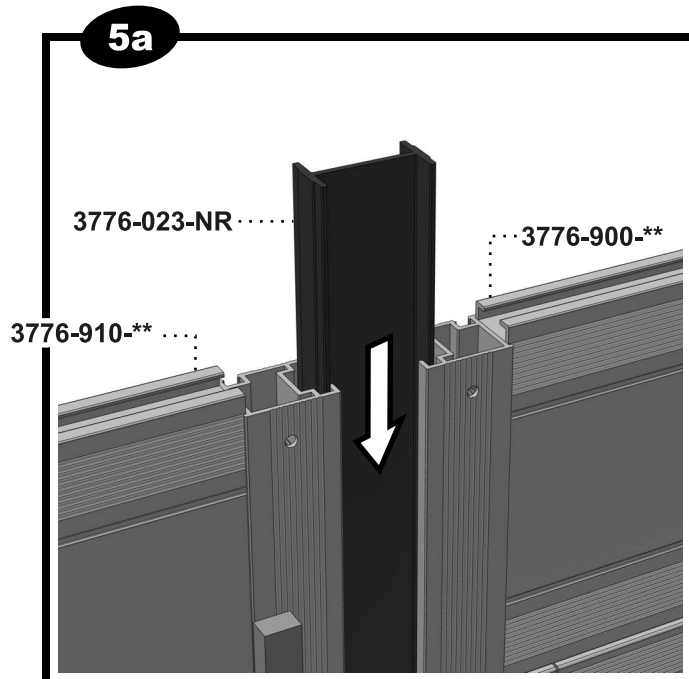

*Vue de l'intérieure - View from inside

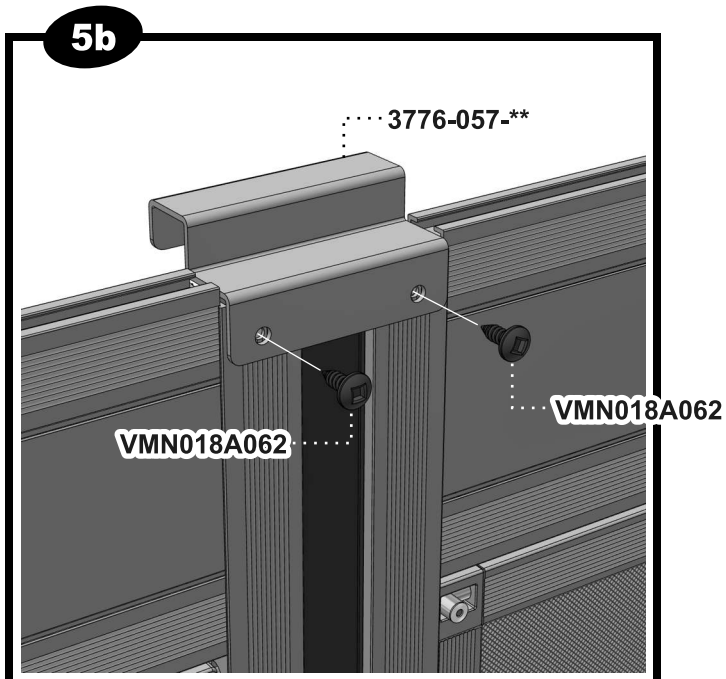

*Vue de l'intérieure - View from inside

** Code couleur - Color code

STEP
Étape 6

x1

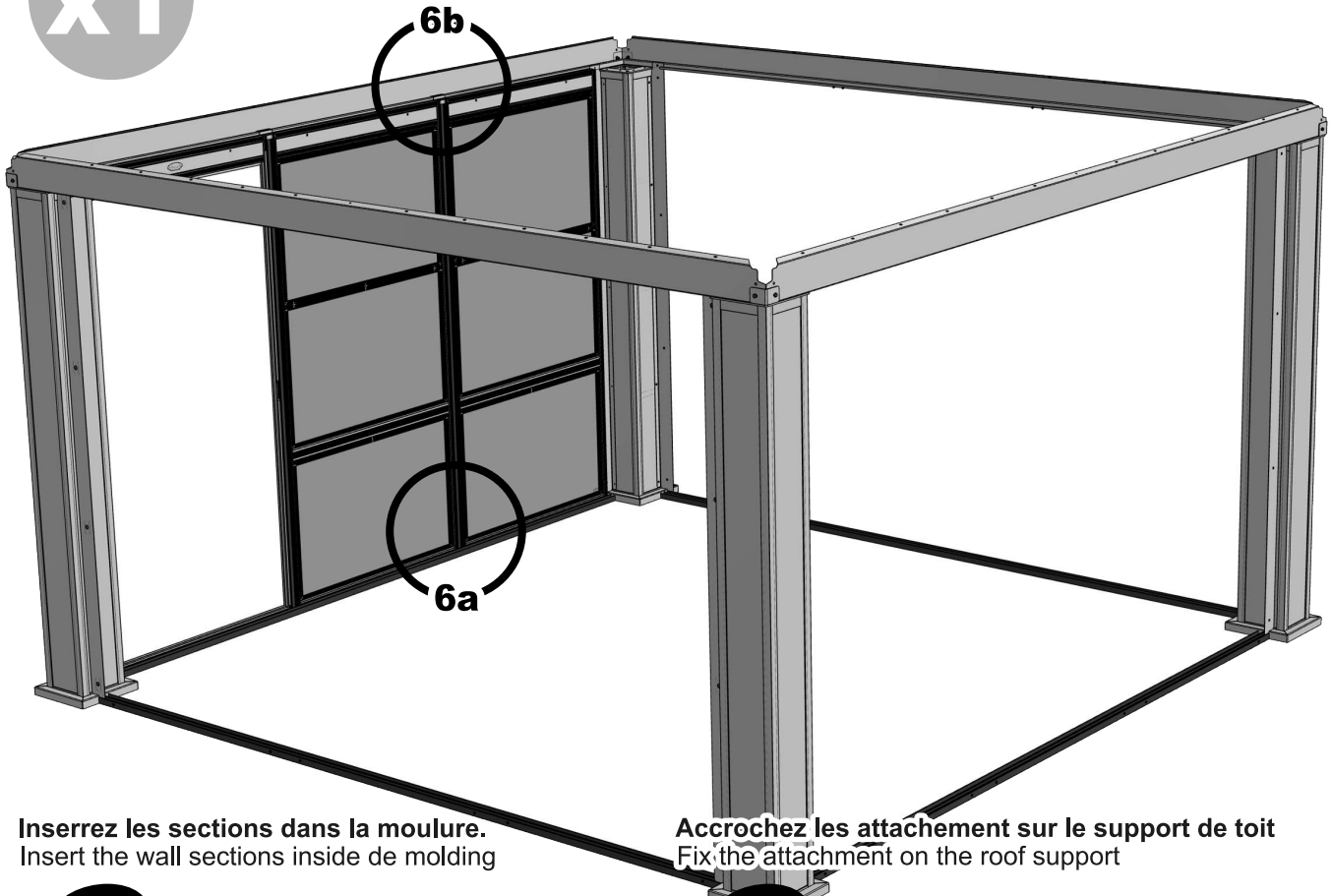

Inserrez les sections dans la moulure.
Insert the wall sections inside de molding

Accrochez les attachement sur le support de toit
Fix the attachment on the roof support

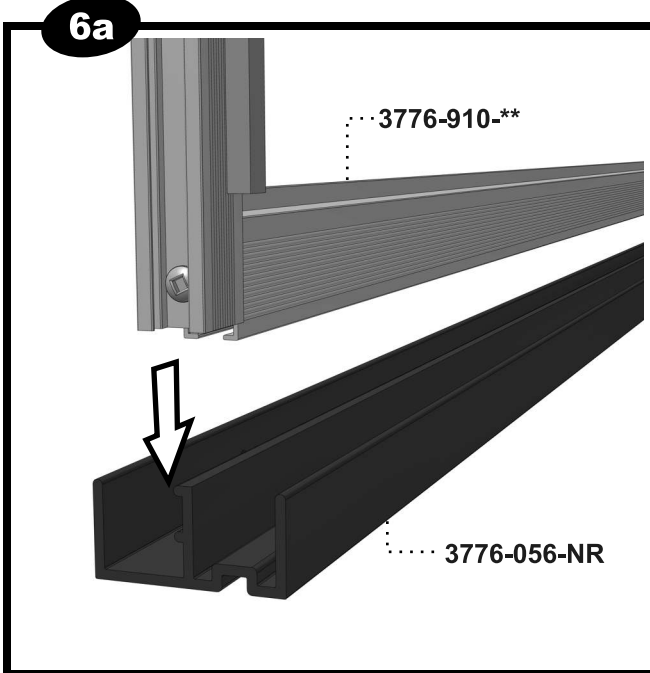

*Vue de l'intérieure - View from inside

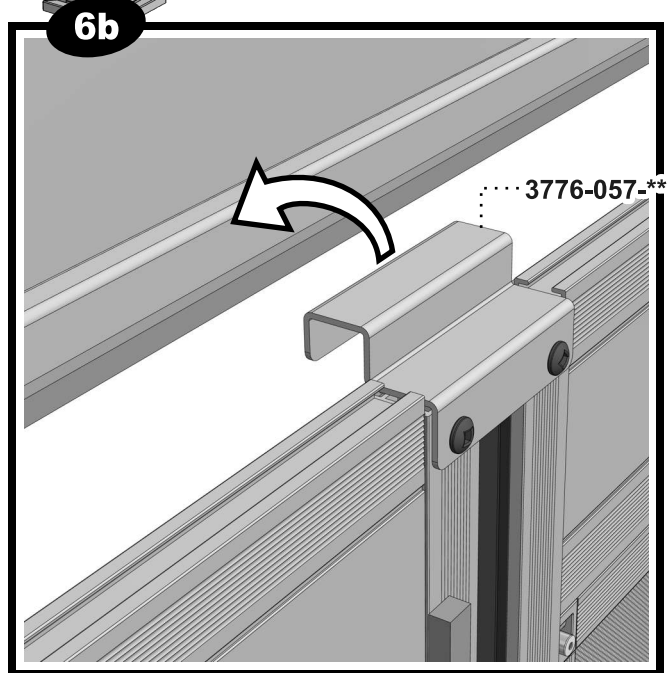

*Vue de l'intérieure - View from inside

** Code couleur - Color code

STEP Étape 7

x1

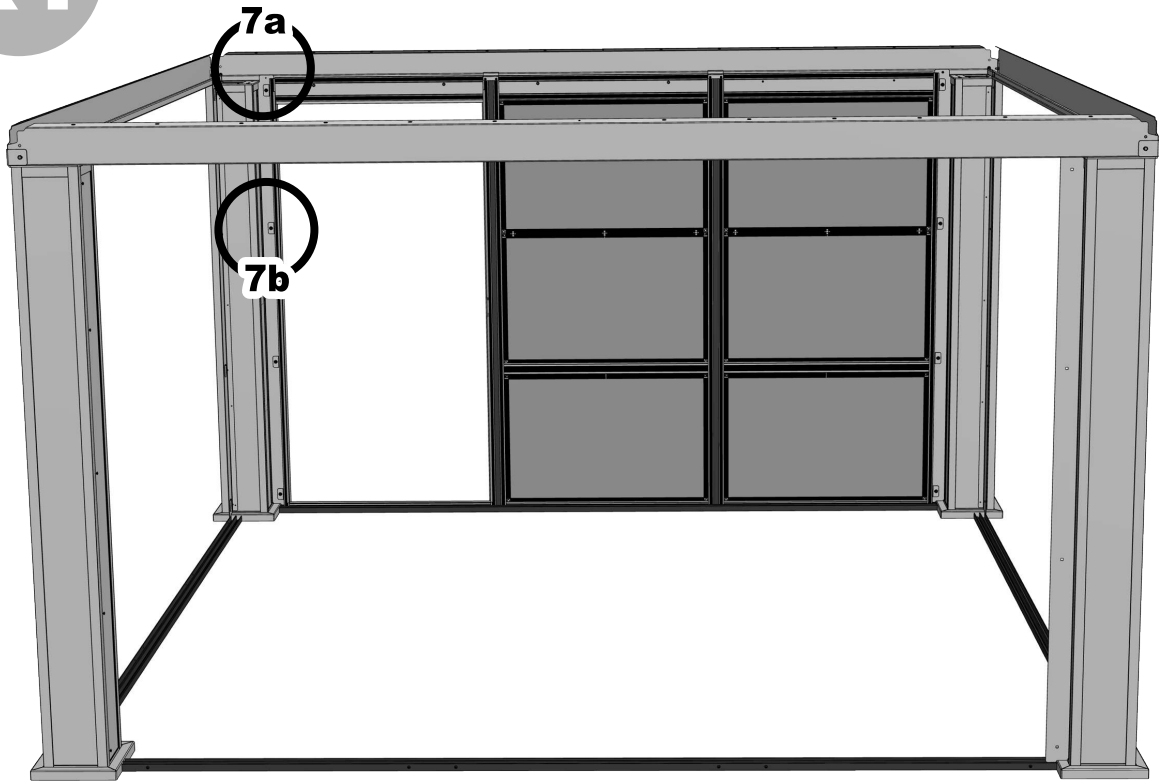

Fixez les bouchons et positionnez le mur à 1 7/8"
Fix the caps and align the wall at 1 7/8"

Fixez le mur a l'aide des attachements.
Fix the wall with the attachments

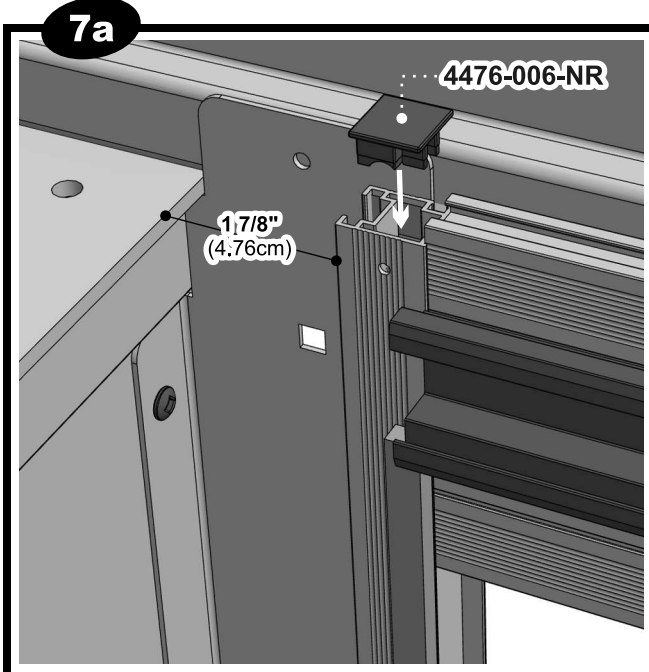

*Vue de l'intérieure - View from inside

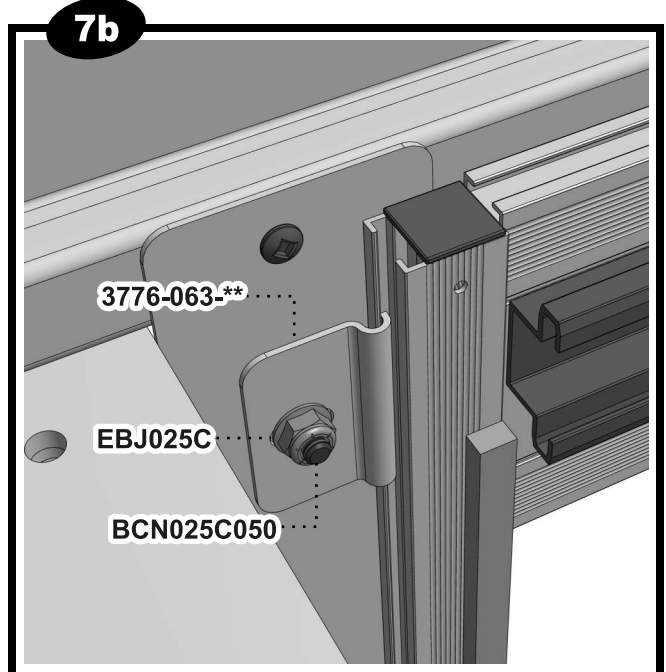

*Vue de l'intérieure - View from inside

** Code couleur - Color code

STEP
Étape 8

x1

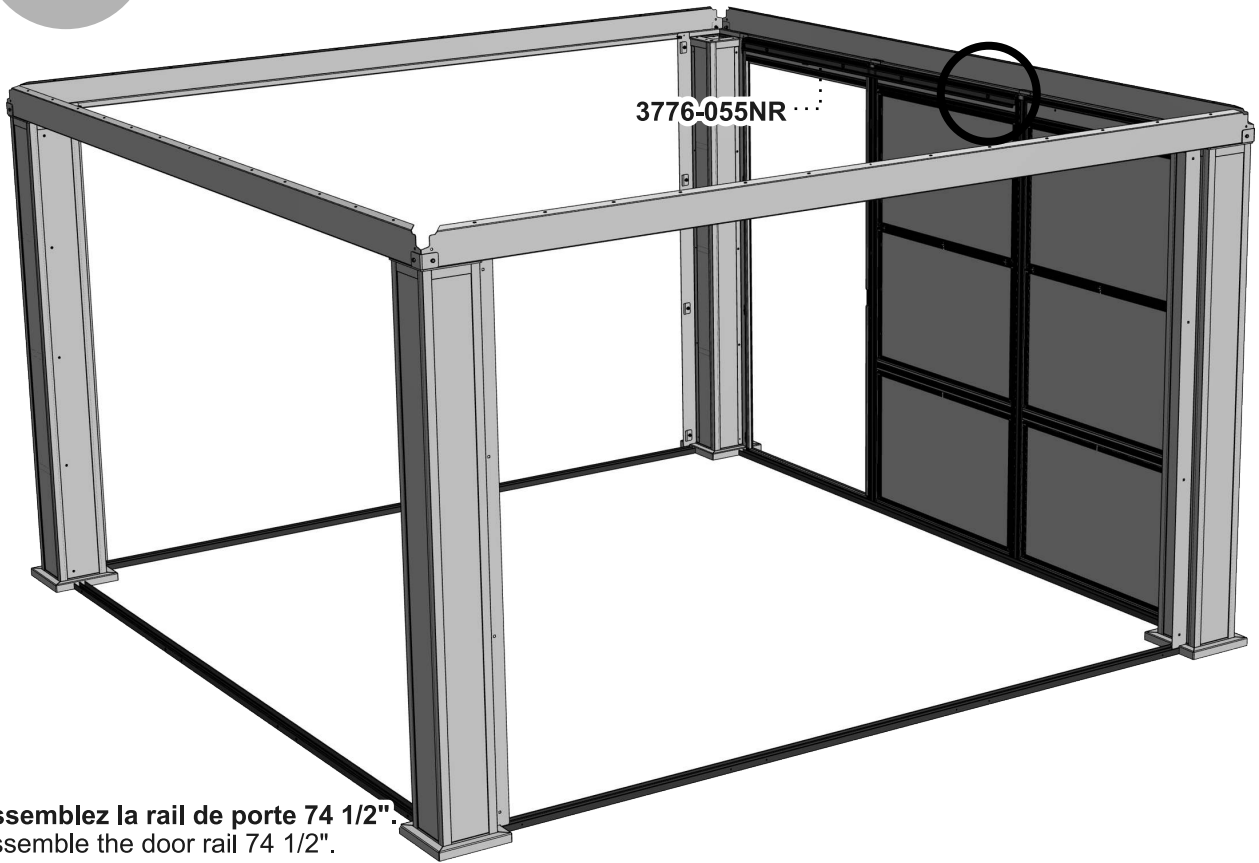

Assemblez la rail de porte 74 1/2".
Assemble the door rail 74 1/2".

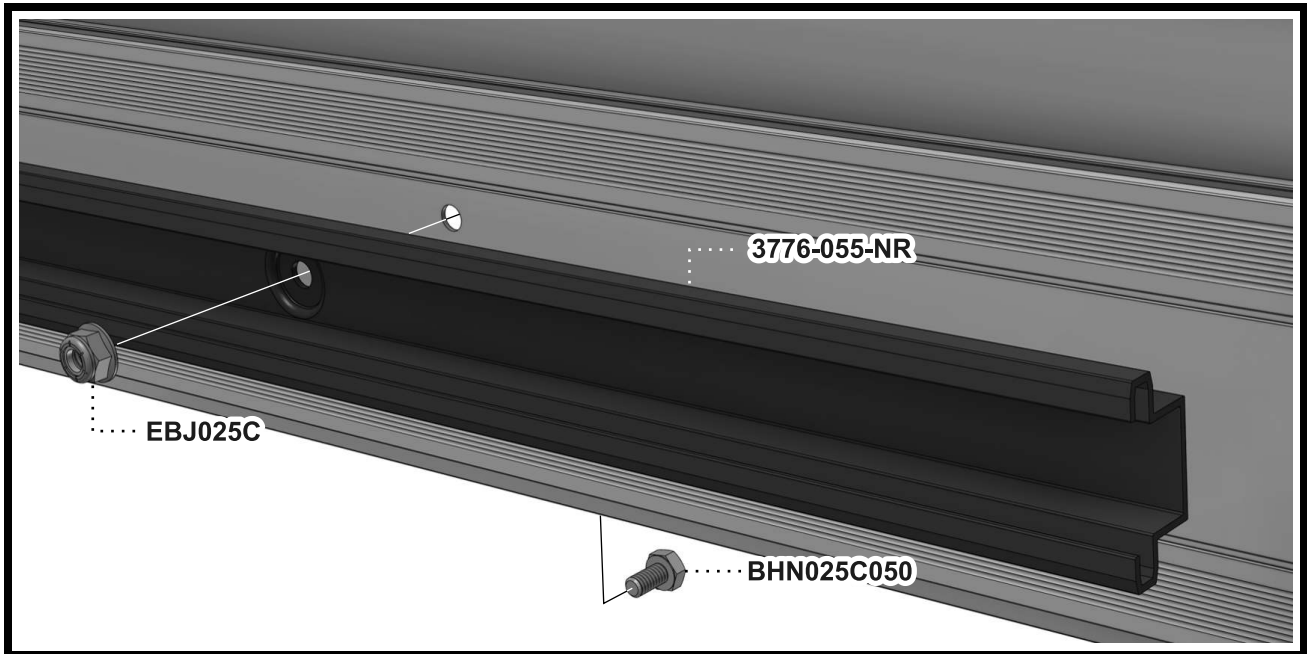

*Vue de l'intérieure - View from inside

** Code couleur - Color code

STEP
Étape 9

x1

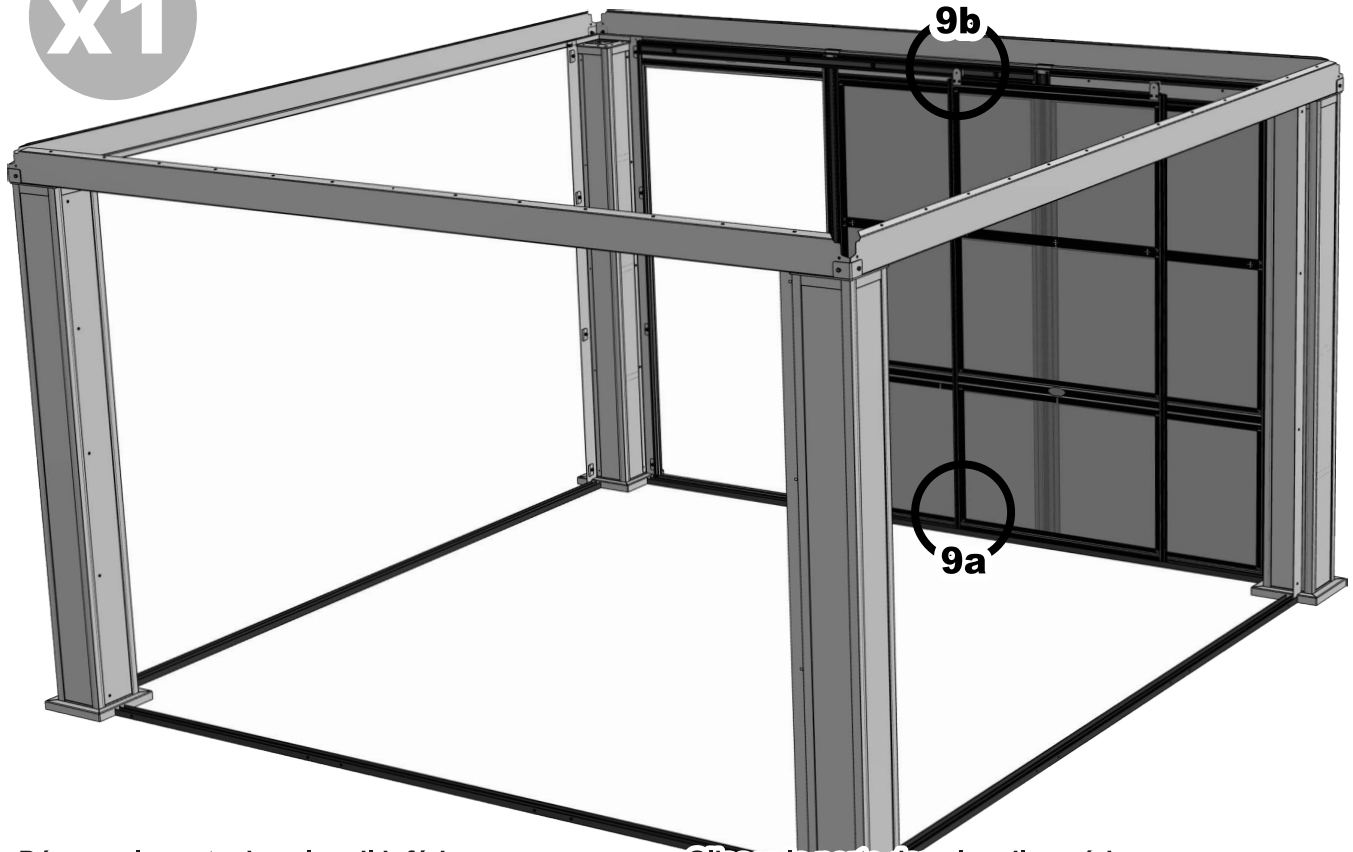

Déposez la porte dans la rail inférieure.
Place the door into the lower rail.

Glissez la porte dans la rail supérieure.
Slide the door into the upper rail.

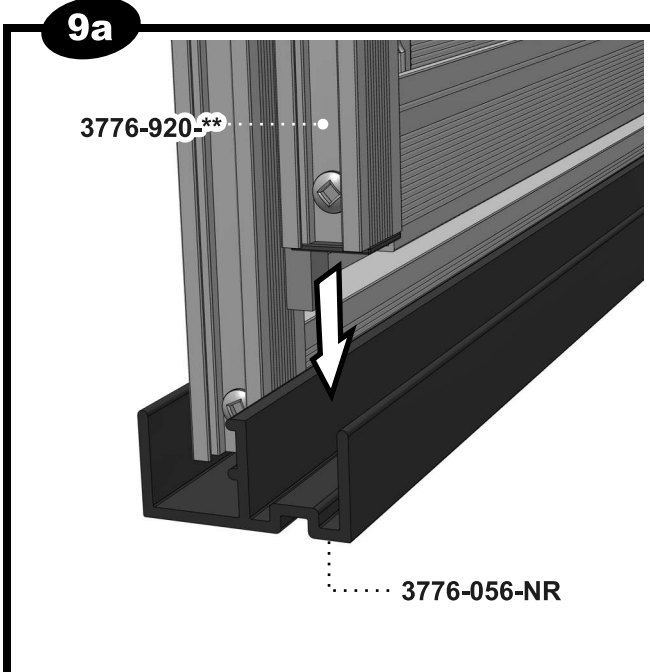

*Vue de l'intérieure - View from inside

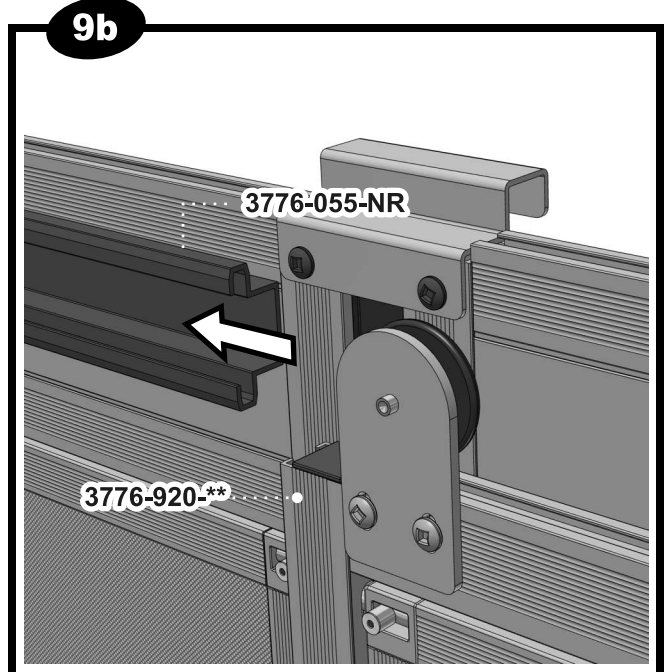

*Vue de l'intérieure - View from inside

** Code couleur - Color code

STEP Étape 10

x1

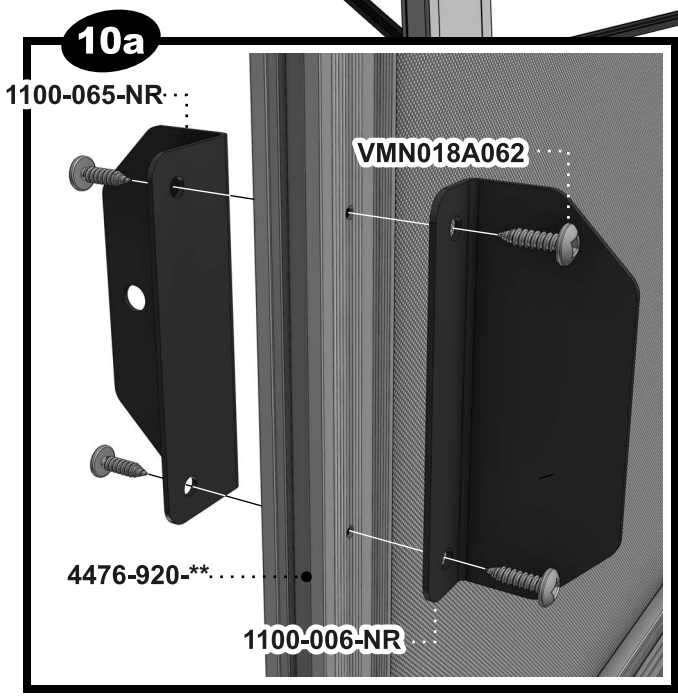
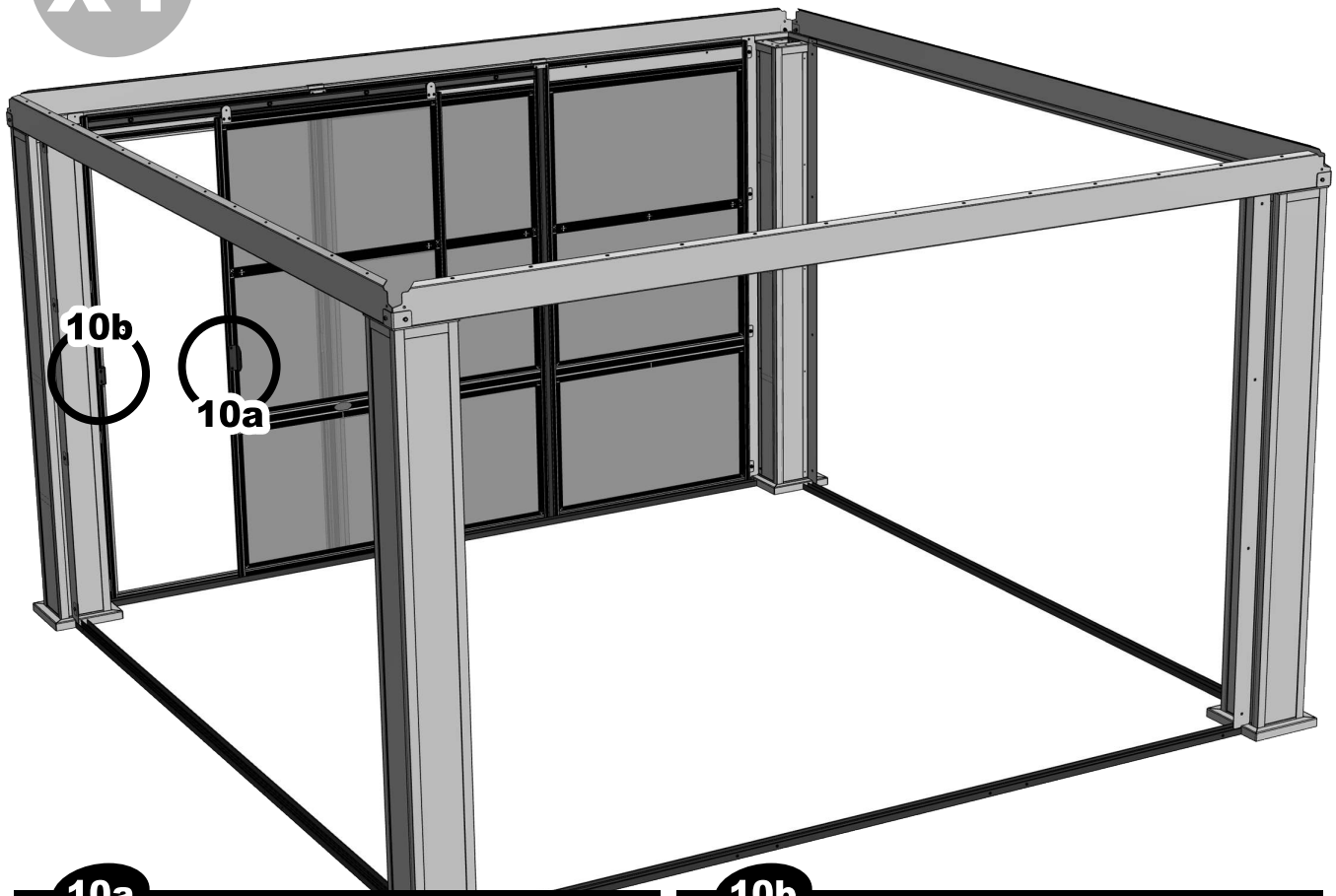

*Vue de l'intérieure - View from inside

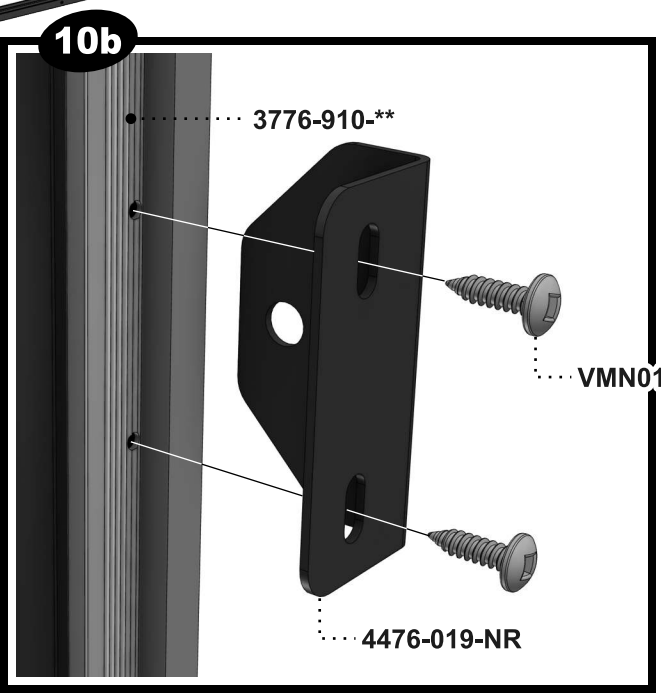

*Vue de l'intérieure - View from inside

** Code couleur - Color code

Ajustements de porte - Door adjustments

Ajustez la porte de façon a ce qu'elle soit aligné avec le cadrage si nécessaire.
Adjust the door aligned with the door frame if necessary.

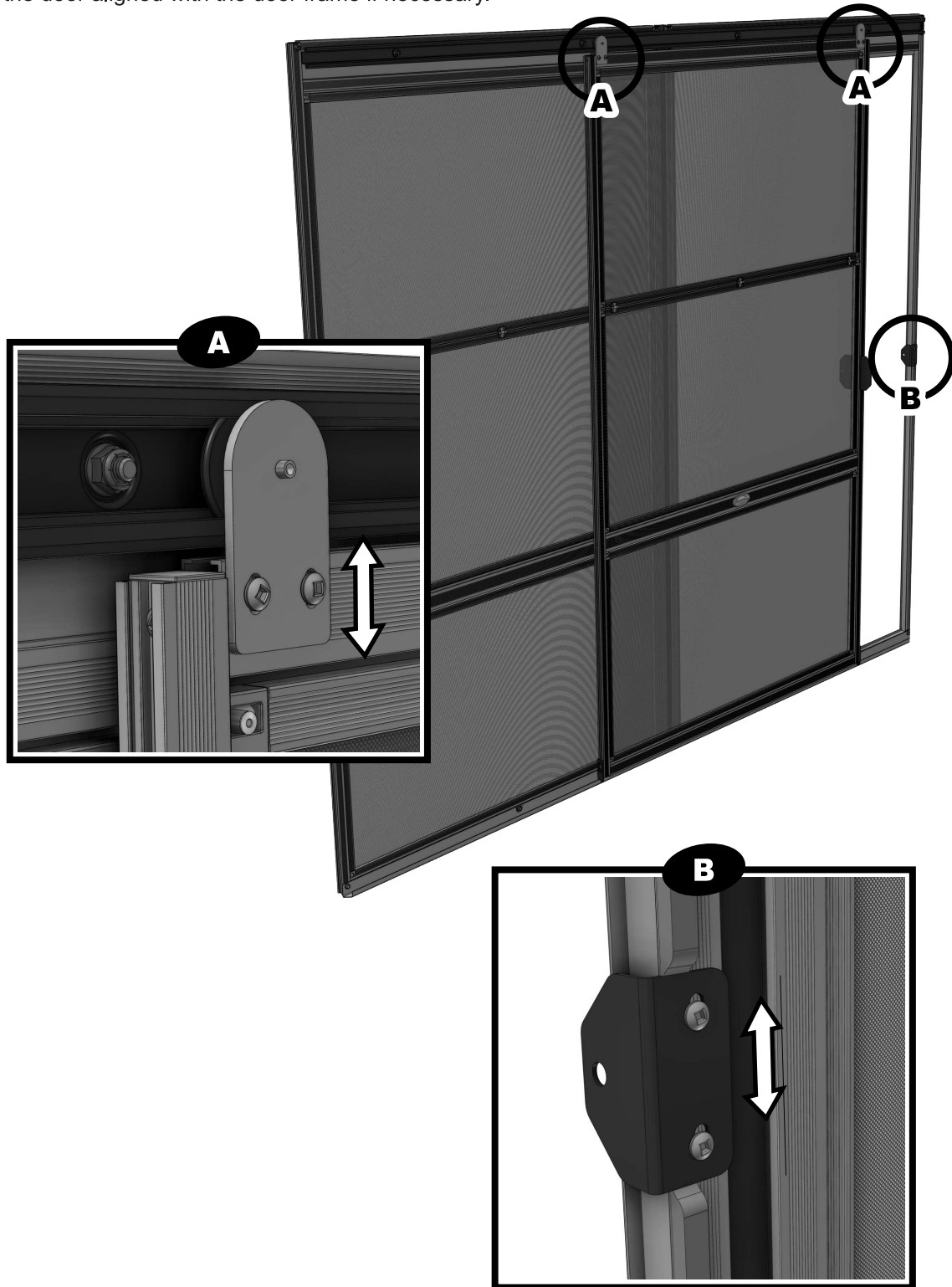

STEP
Étape 12
 x3

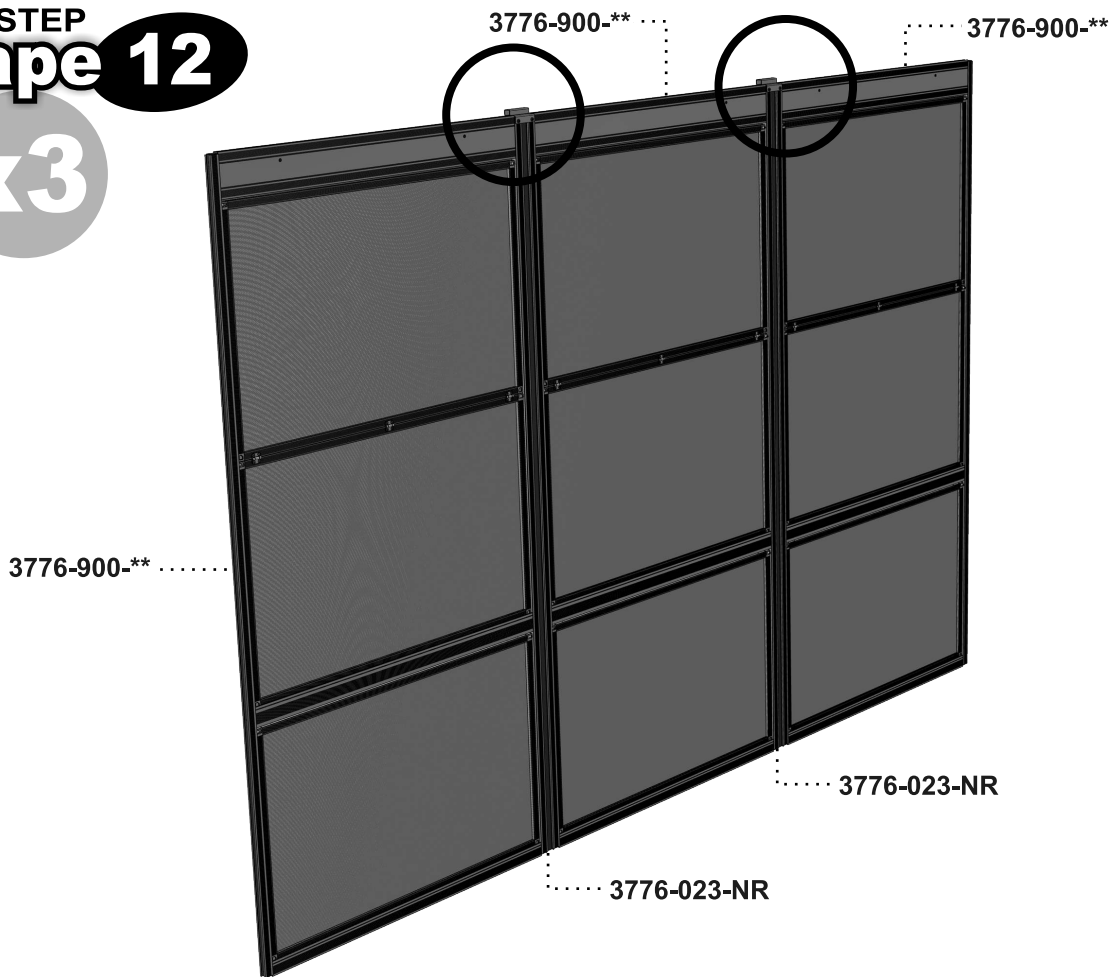

Assemblez les sections moustiquaire
 Assemble the screen sections

12a

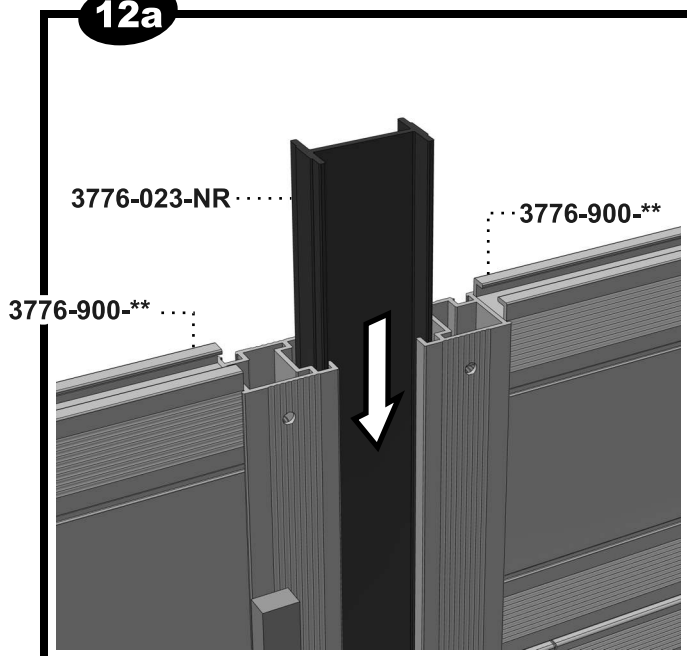

*Vue de l'intérieure - View from inside

12b

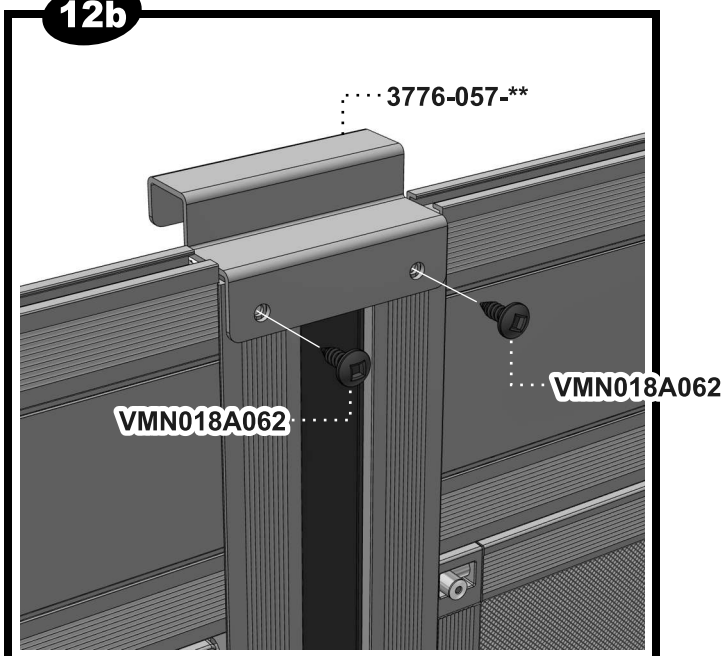

*Vue de l'intérieure - View from inside

** Code couleur - Color code

STEP Étape 13

x3

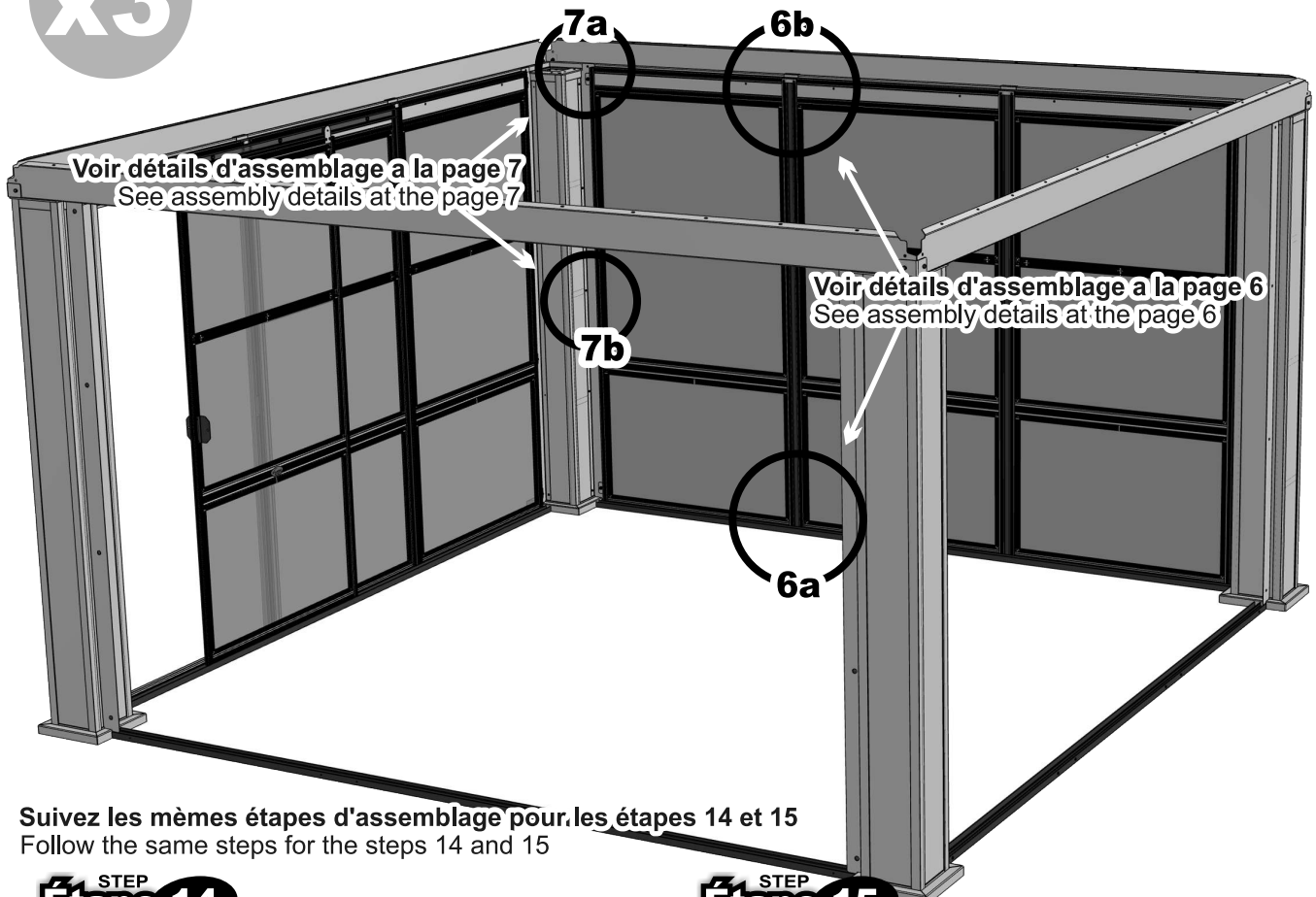

Suivez les mêmes étapes d'assemblage pour les étapes 14 et 15
Follow the same steps for the steps 14 and 15

STEP Étape 14



STEP Étape 15

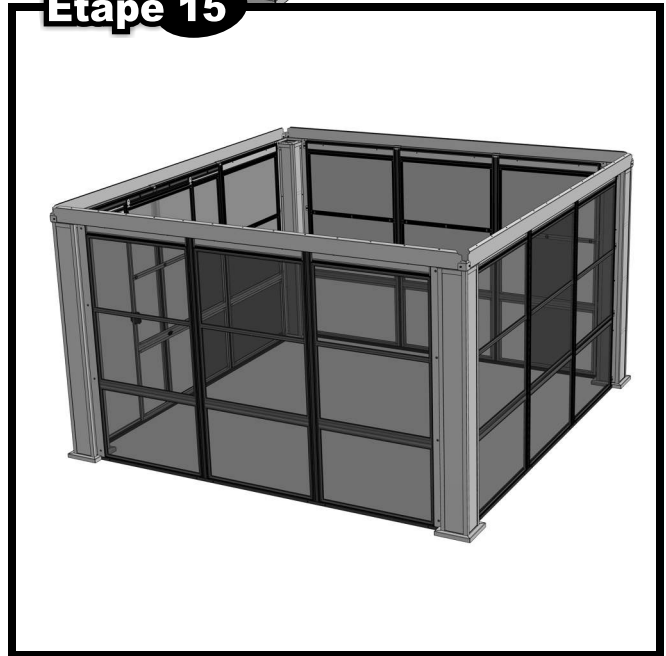

STEP
Étape 16

x4

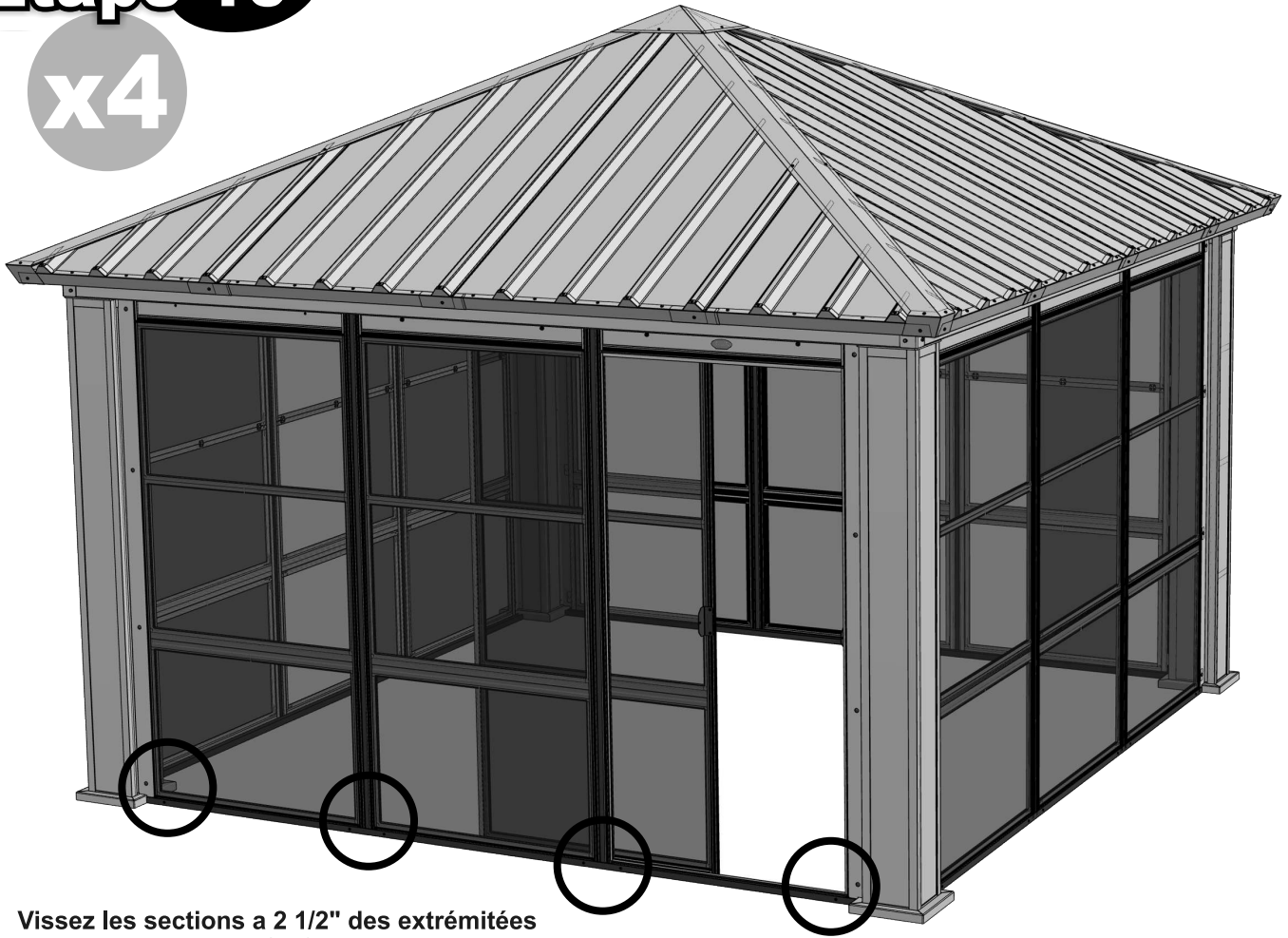

Vissez les sections a 2 1/2" des extrémités
Fix the sections at 2 1/2" from each sides

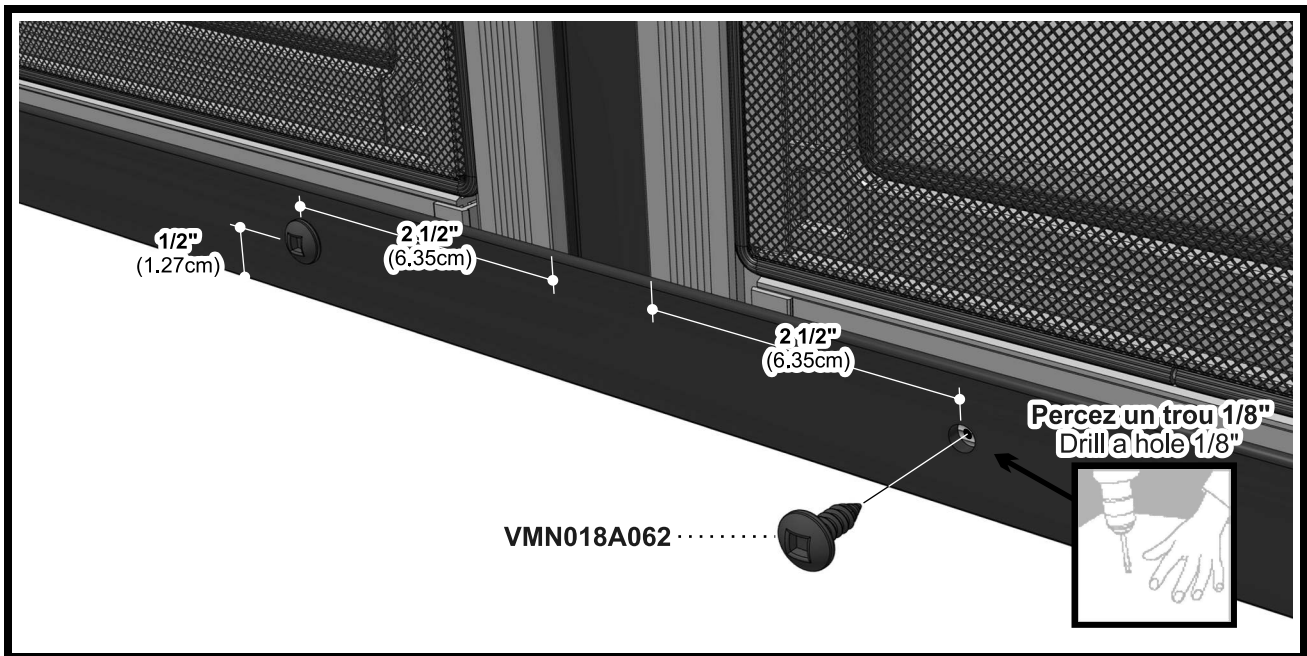

Liste de pièces - Parts list

MS1212

Item No.	Description française	English description	Qté/Qty
1100-006-NR	Poignée de porte	Door handle	1
1100-065-NR	Poignée de porte trouée	Perforated door handle	1
3776-023-NR	Paumelle en PVC 76 5/8"	PVC Hinge 76 5/8"	8
3776-055-NR	Rail de porte 74 1/2"	Door rail 74 1/2"	1
3776-056-NR	Assise double 116 1/2"	Lower rail 116 1/2"	4
3776-057-**	Crochet de section	Section hook	8
3776-062	Foam 115"	Foam 115"	4
3776-063-**	Attachement de section	Section attachment	32
3776-070-**	Montant gauche 76 3/8"	Left angle 76 3/8"	4
3776-071-**	Montant droit 76 3/8"	Right angle 76 3/8"	4
3776-900-**	Section régulière 37 3/4" x 76 7/8"	Regular section 37 3/4" x 76 7/8"	11
3776-910-**	Cadre de porte 37 3/4" x 76 7/8"	Door frame 37 3/4" x 76 7/8"	1
3776-920-**	Porte coulissante 37 3/4" x 74"	Sliding door 37 3/4" x 74"	1
4476-006-NR	Bouchon de section	Section cap	8
4476-019-NR	Barrure de porte	Door lock	1
BCN025C050	Boulon de carrosserie 1/4-20 x 1/2"	Carriage bolt 1/4-20 x 1/2"	32
BHN025C050	Boulon hexagonal 1/4-20 x 1/2"	Hexagonal bolt 1/4-20 x 1/2"	4
EBJ025C	Écrou de blocage 1/4-20	Lock nut 1/4-20	36
VMN018A062	Vis mécanique #10 Type-A x 5/8"	Machine screw #10 Type-A x 5/8"	94

Notice!

- L 'assemblage est plus facile à deux.
 - Doit être fixé à sa base sur un plancher de bois ou de béton.
 - Placez les pièces et outils de façon à ce qu'elles soient à la portée de main.
 - Attention de ne pas endommager les pièces lors de l'installation.
 - Durant la saison hivernal, si une neige mouillante colle sur le toit et accumule un poids dépassant 3 lbs au pieds carré, veuillez dégager ce surplus de poids afin d'éviter d'endommager la structure.
 - Ce gazebo se lave à l'eau avec un savon doux. Vous pouvez utiliser le savon pour le lavage de votre automobile.
-

- Assembly is easier with helper.
- Must be fixed on a wooden or cement floor.
- Arrange parts and necessary tools in order to be available at any time.
- Pay attention to every parts that could be damaged during the assembly.
- During the winter season, if a wet snow sticks on the roof and accumulate a weight of a maximum of more than 3 pounds per square foot, remove the snow, to avoid damages to the frame.
- This gazebo can be washed with water and soft soap. You can also use the special soap recommended to wash your car.



VERANDA JARDIN INC.

2200 Louis-Félix, Drummondville, Québec, J2C 6E5

Tél.: (819) 477-3005 - Fax (819) 477-1228

info@verandajardin.com

**Pour plus amples renseignements sur nos produits
visitez notre site internet www.verandajardin.com**

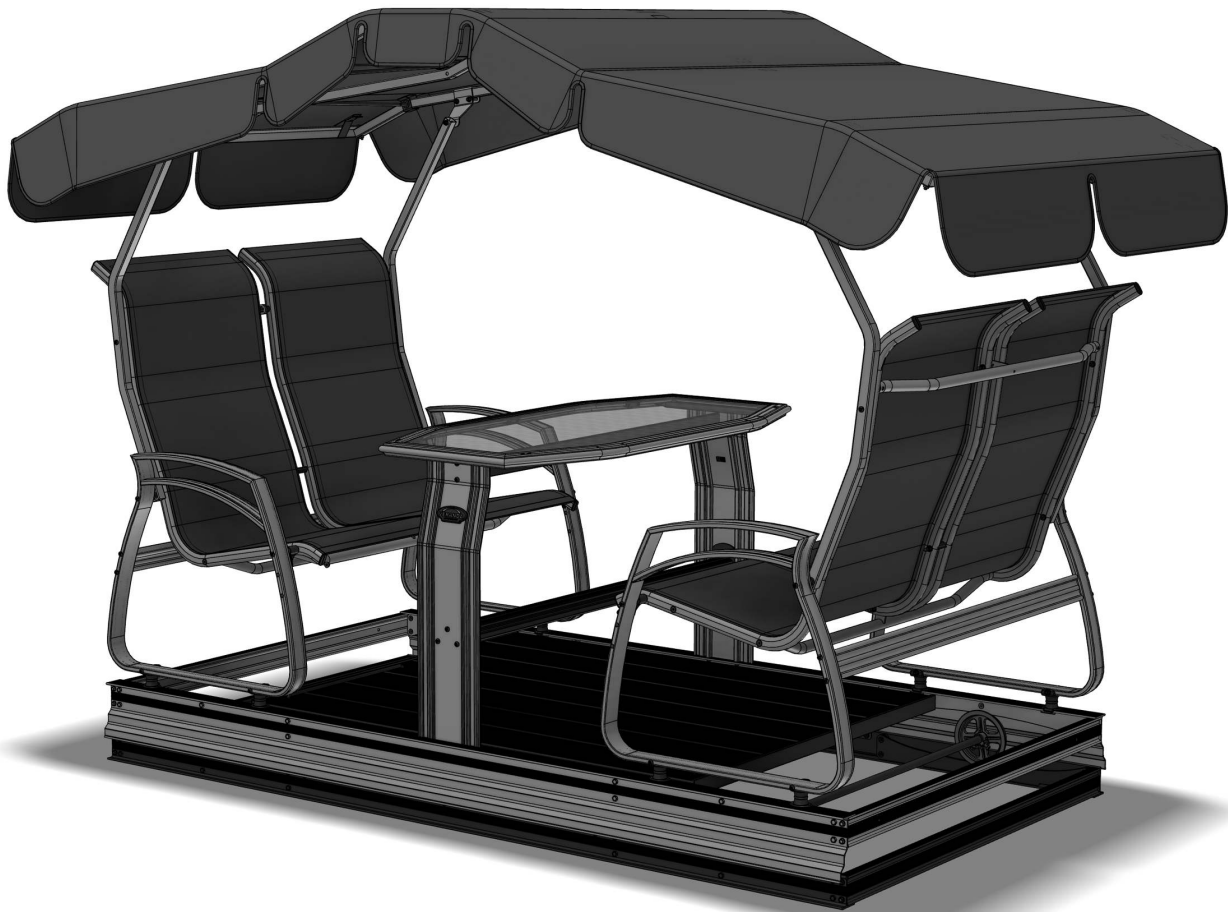



**For other informations on our products visit our web site
www.verandajardin.com**



VERANDA JARDIN INC.

2200 Louis-Félix, Drummondville, Québec, J2C 6E5

Tél.: (819) 477-3005 - Fax (819) 477-1228

info@verandajardin.com

**Pour plus amples renseignements sur nos produits
visitez notre site internet www.verandajardin.com**



**For other informations on our products visit our web site
www.verandajardin.com**

Modèle - Model

Code couleur - Color code

MS1212-**