

ASSEMBLY INSTRUCTIONS FOR "GA" MODULAR BUILDINGS ALL MODELS

W01

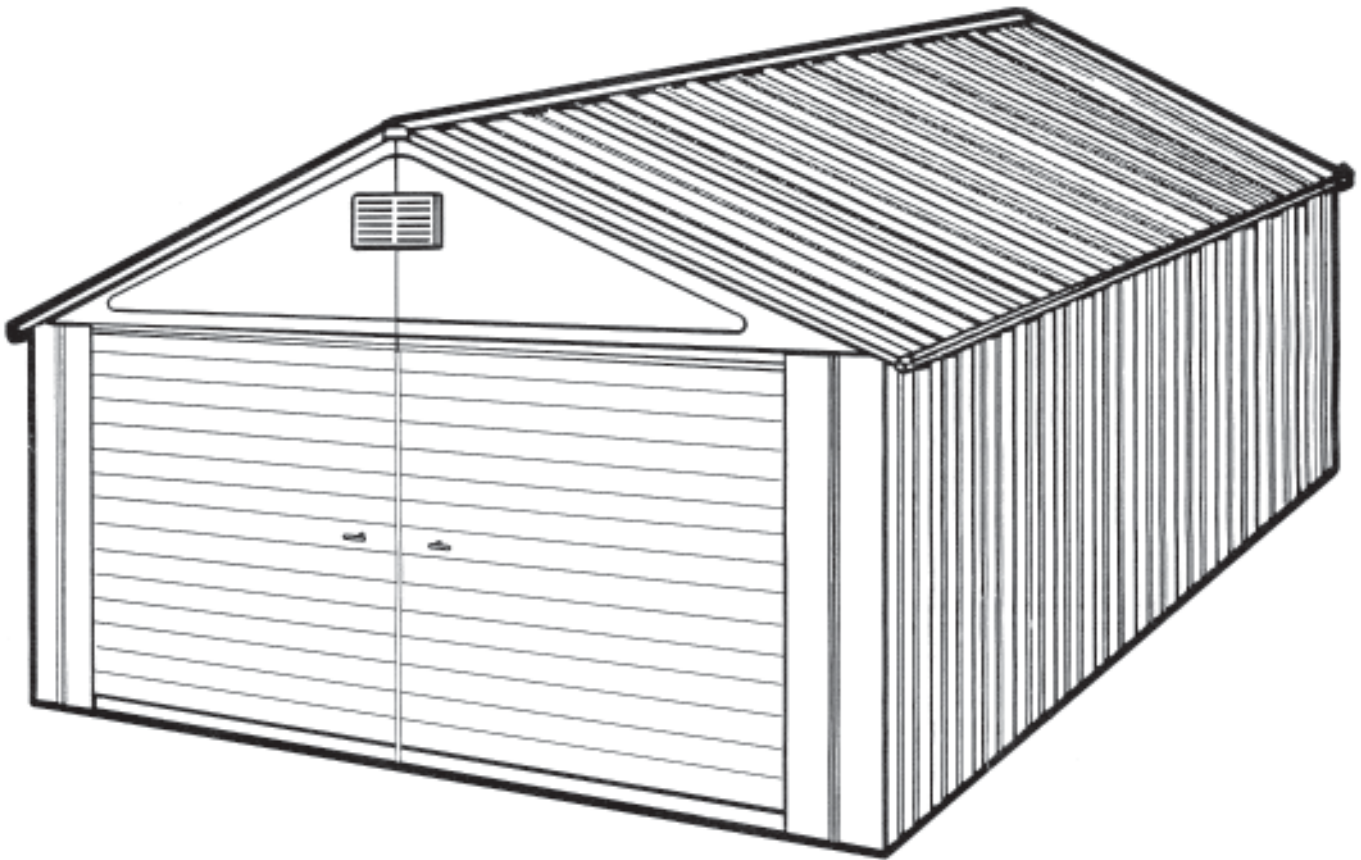

CAUTION: Some parts have sharp edges. Care must be taken when handling the various pieces to avoid a mishap. For safety sake, please read the safety information provided in this manual before beginning construction. Wear gloves when handling metal parts.

VERSION FRANÇAISE AU DOS

BEFORE STARTING TO ERECT YOUR BUILDING...

we advise you to contact the local authority where the building is to be erected, with regards to any permit that may be required.

FOR NORTH AMERICA: This building has a load carrying capacity of 27.5 psf live load on the horizontal projection of the roof in accordance with CSA std. S136M89.

FOR EUROPE ONLY: This building has sufficient loadbearing capacity for a snow load of $S_o = 0.75 \text{ kNm}^2$ and for wind loads as per DIN 1055, sheet 4, or for a combination of loads, as per Expertise no. 9700407 dated April 18, 1997 from VSL Consulting Engineers for Light Construction, Karlsruhe, Germany and documented in VA reports nos. 963002 and 963041. This document is available upon request from purchaser.

CONTENTS

- Pre-construction instructions
- Assembling the building
- Parts list and ordering information
- Anchoring the frame

TO ENABLE YOU TO BECOME FAMILIAR WITH YOUR BUILDING, PLEASE READ THE FOLLOWING

Your building has been delivered to you in the following manner:

This master carton which you have opened first contains the front and rear sections of your building. In fact, if all the components in this carton were assembled you would have a complete building 3.05 m x 1.52 m (10' x 5'). To allow for various sizes of buildings, the remaining sections have been shipped in module packs of either 1.22 m, 1.83 m and 2.44 m (4', 6' and 8') sections.

Example 1: You require a 3.05 m x 4.58 m (10' x 15') building, you receive 1 x 1.52 m (5') master carton and 1 x 1.22 m (4') carton and 1 x 1.83 m (6') carton.

Example 2: You require a 3.05 m x 7.62 m (10' x 25') building, you receive 1 x 1.52 m (5') master carton, 2 x 2.44 m (8') cartons and 1 x 1.22 m (4') carton.

After opening your cartons you will have all the parts required to complete your building. Each carton contains the amount of hardware necessary to assemble that section.

PROCEED WITH CONFIDENCE

It might look complicated when you first unpack your building...but it really isn't. Simply follow the illustrated instructions and your building will go up quickly and accurately.

ASSEMBLY INSTRUCTIONS

- **Before you start...** read through instructions carefully!
- **You will need assistance...** you'll find that the assistance of at least two other people will speed the job and make assembly easier.
- **Selecting your site...** choose an area that's firm and level yet allows drainage away from site. **WARNING!** ... DO NOT ERECT YOUR BUILDING IN AREAS THAT ARE SUBJECTED TO HIGH WINDS, OR ERECT ON A WINDY DAY. ANY BUILDING LEFT PARTIALLY CONSTRUCTED MAY BE SERIOUSLY DAMAGED IF LEFT IN THIS STATE.
- **Sort and separate all parts and hardware ...** checking with the illustrations on Pages 5, 6, 7 and the table on Pages 8 and 9. Be sure you have all parts and know where they belong in the building. Each part has been numbered and illustrated, the quantity required and its part number noted.
- **Follow step by step instructions carefully...** complete each step before going on to the next one.
- **Retain this manual after assembly is completed...** it contains a complete parts list.

STAMPED
PART #

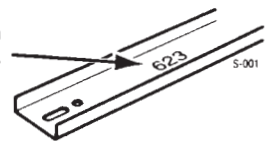

TOOLS REQUIRED

- 2 Phillips N° 2 screwdrivers (magnetized recommended)
(2 Electric screwdrivers recommended)
- 2 x 10mm (3/8") Offset Wrenches or socket set
- Pair of pliers
- Large set square
- Steel tape measure 4.88m (16 ft.)
- Carpenter's level
- Electric hammer drill (1/2" chuck)
Used for levelling and anchoring building
- 2 Step ladders 1.52m (5 ft.)
- Chalk line
- Safety glasses, work gloves
- Spade or shovel

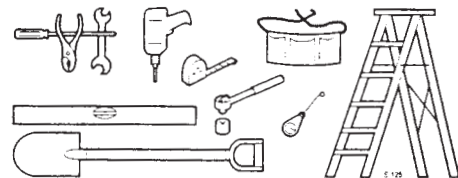

PREPARATION OF BUILDING SITE

This building must be constructed on a **SOLID AND LEVEL BASE FOUNDATION**. We recommend a poured concrete pad for a floor and base. *Make sure your foundation area is firm and will allow drainage away from the site.* A slight incline around the perimeter of the pad is recommended to allow drainage of water away from the wall panels. Make your solid base foundation at least 30cm (12") larger than your building's base rail dimensions. Refer to the chart on Page 4 for base dimensions.



This building could also be constructed on a wooden base (floor) or wood frame, depending on requirements for permits. The owner or installer should choose the type of base (concrete or wood) prior to installation. **The manufacturer is not responsible for the choice and the construction of the base.**

NOTE 1: To construct the concrete pad, first prepare a level bed of compacted crushed stone. A concrete pad should then be poured to a thickness of 15cm (6"). When completed, allow to harden thoroughly for at least 48 hours.

NOTE 2: The foundation should be extended accordingly with the number of extension modules purchased.

YOUR BUILDING MUST BE ANCHORED

Your building must be firmly anchored to your concrete pad...to help protect against damage from high winds. Check the anchoring procedure and hardware required on Page 38 NOW!

NOTE: Building anchors are NOT supplied as part of the hardware package and may be purchased locally. Further anchoring instructions follow after all wall and roof panels have been installed.

MODULAR BUILDING COMPONENTS

GA Modular Buildings are available in a master module of 152 cm (5') and extension modules of 122 cm (4'), 183 cm (6') and 244 cm (8'). The 152 cm (5') master module contains the front and back walls.

The extension modules can be used in any combination and sequence with the 152 cm (5') master module and in any desired quantity. See the illustration below for sizes and as a guide.

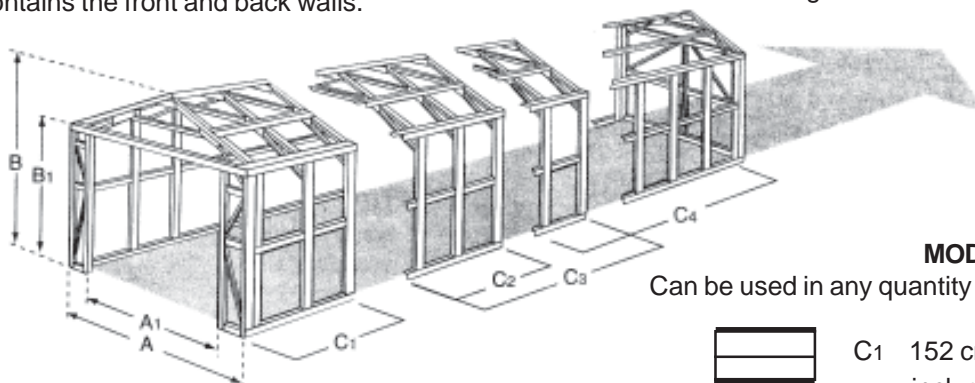

DIMENSIONS - cm (inches)

A	A1	B	B1
307 (121)	236 (93)	243 (95.7)	190 (74.8)

MODULES

Can be used in any quantity and sequence with C1 module

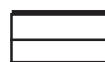

C1 152 cm (5') master module includes front and back walls

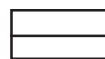

C2 122 cm (4') extension

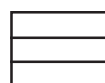

C3 183 cm (6') extension

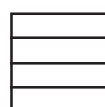

C4 244cm (8') extension

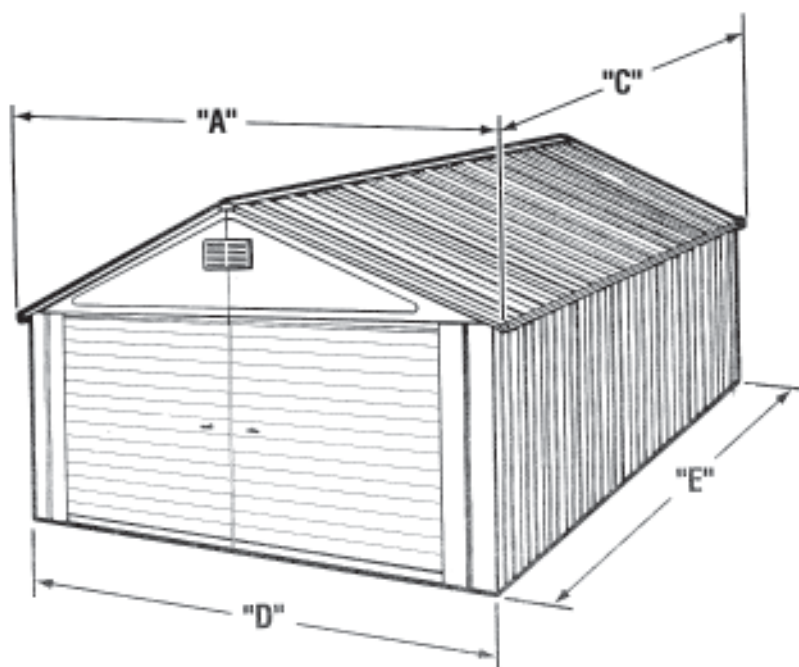

**OVERALL MEASUREMENTS OF BUILDING
(ROOF DIMENSIONS)**

MAXIMUM OUTSIDE DIMENSIONS OF BASE RAILS

Model	"A" cm (in.)	"C" cm (in.)	"D" cm (in.)	"E" cm (in.)
GA105	307.3cm (121.0")	153.6cm (60.5")	293.3cm (115.5")	142.2cm (56.0")
GA109	307.3cm (121.0")	278.1cm (109.5")	293.3cm (115.5")	266.7cm (105.0")
GA1011	307.3cm (121.0")	340.4cm (134.0")	293.3cm (115.5")	328.9cm (129.5")
GA1013	307.3cm (121.0")	402.6cm (158.5")	293.3cm (115.5")	391.1cm (154.0")
GA1015	307.3cm (121.0")	464.8cm (183.0")	293.3cm (115.5")	453.4cm (178.5")
GA1017	307.3cm (121.0")	527.0cm (207.5")	293.3cm (115.5")	515.6cm (203.0")
GA1019	307.3cm (121.0")	589.2cm (232.0")	293.3cm (115.5")	577.8cm (227.5")
GA1021	307.3cm (121.0")	651.5cm (256.5")	293.3cm (115.5")	640.1cm (252.0")
GA1023	307.3cm (121.0")	713.7cm (281.0")	293.3cm (115.5")	702.3cm (276.5")
GA1025	307.3cm (121.0")	775.9cm (305.5")	293.3cm (115.5")	764.5cm (301.0")
GA1027	307.3cm (121.0")	838.2cm (330.0")	293.3cm (115.5")	826.8cm (325.5")
GA1029	307.3cm (121.0")	900.4cm (354.5")	293.3cm (115.5")	889.0cm (350.0")
GA1031	307.3cm (121.0")	962.7cm (379.0")	293.3cm (115.5")	951.2cm (374.5")
GA1033	307.3cm (121.0")	1024.8cm (403.5")	293.3cm (115.5")	1013.5cm (399.0")
GA1035	307.3cm (121.0")	1087.1cm (428.0")	293.3cm (115.5")	1075.7cm (423.5")

ENTRANCE DIMENSIONS:	HEIGHT	190.5 cm	75.0 in.
	WIDTH	236.2 cm	93.0 in.
INSIDE HEADROOM:		207.0 cm	81.5 in.

Dimensions "C" and "E" may change depending on the number and configuration of modules purchased. Use this table as a guide.

SMALL PARTS

NOTE: DRAWINGS ARE NOT TO SCALE. BUT ARE DESIGNED TO SHOW CROSS SECTIONS AND GENERAL CONFIGURATION TO AID IDENTIFICATION



**N° 40H/50H
TAPE**

**N° 60H
ROOF CORNER CAP
(included in
hardware pack)**



HARDWARE PACKAGES	
12-005P	1.52m (5') MASTER PACK
12-004P	1.22m (4') MODULE PACK
12-006P	1.83m (6') MODULE PACK
12-008P	2.44m (8') MODULE PACK



**RIDGE COVER
END CAP
N° 49H**

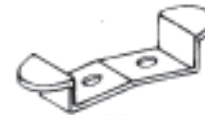

**N° 2
RIDGE COVER
MOUNTING BRACKET**

**N° 19-020
CANE BAR
BRACKET
- BENT**

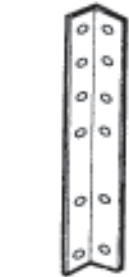

**N° 33
GABLE BRACKET**



**N° 1031
TRUSS ANGLE BRACKET**

**N° C14
LOCK SPACER**



**N° 19-023
CANE BAR
ASSEMBLY**

**N° C15
DOOR SPACER**



**N° 12-220
TINNERMAN
NUT**



**N° 44
REINFORCEMENT
TRUSS PLATE**



**N° DH14
DOOR HANDLE
KIT**

**N° 19-028
STEEL
WASHER**



**N° 19-030
HANDLE
COVER**

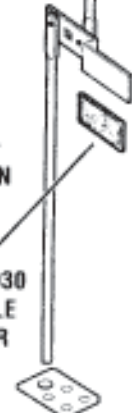

**N° 13-100
LOUVER**



**N° 4L
HINGE**

**N° 19-021
CANE BAR
BRACKET**



**N° 13-007
EMBLEM (Optional)**

**N° 1
VERTICAL POST LINK**



**N° BT1A
FOAM TAPE**

**N° 19-000F
DOOR EXTRUSION**

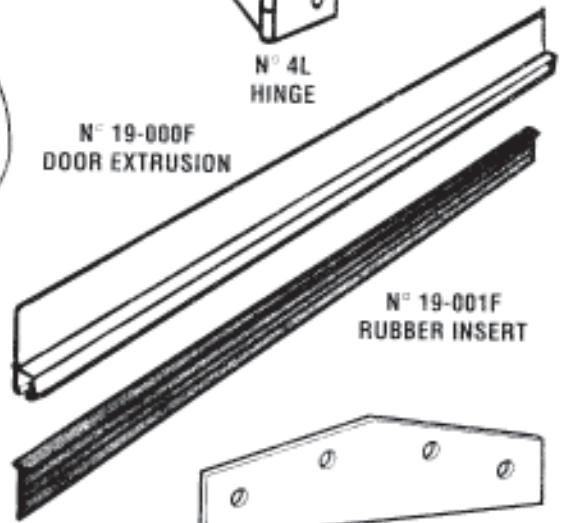

**N° 80
DOUBLE SIDED
TAPE**



**N° 19-001F
RUBBER INSERT**



**N° 1033
DOOR FRAME
ANCHORING BRACKET**

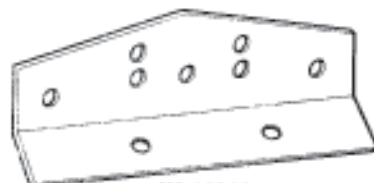

**N° 1029B
REAR CENTRE BRACKET**

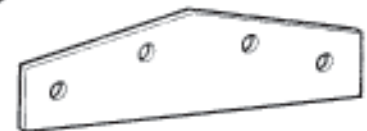

**N° 1029
TRUSS CENTRE BRACKET**

LARGER PARTS

NOTE: DRAWINGS ARE NOT TO SCALE, BUT ARE DESIGNED TO SHOW CROSS SECTIONS AND GENERAL CONFIGURATION TO AID IDENTIFICATION

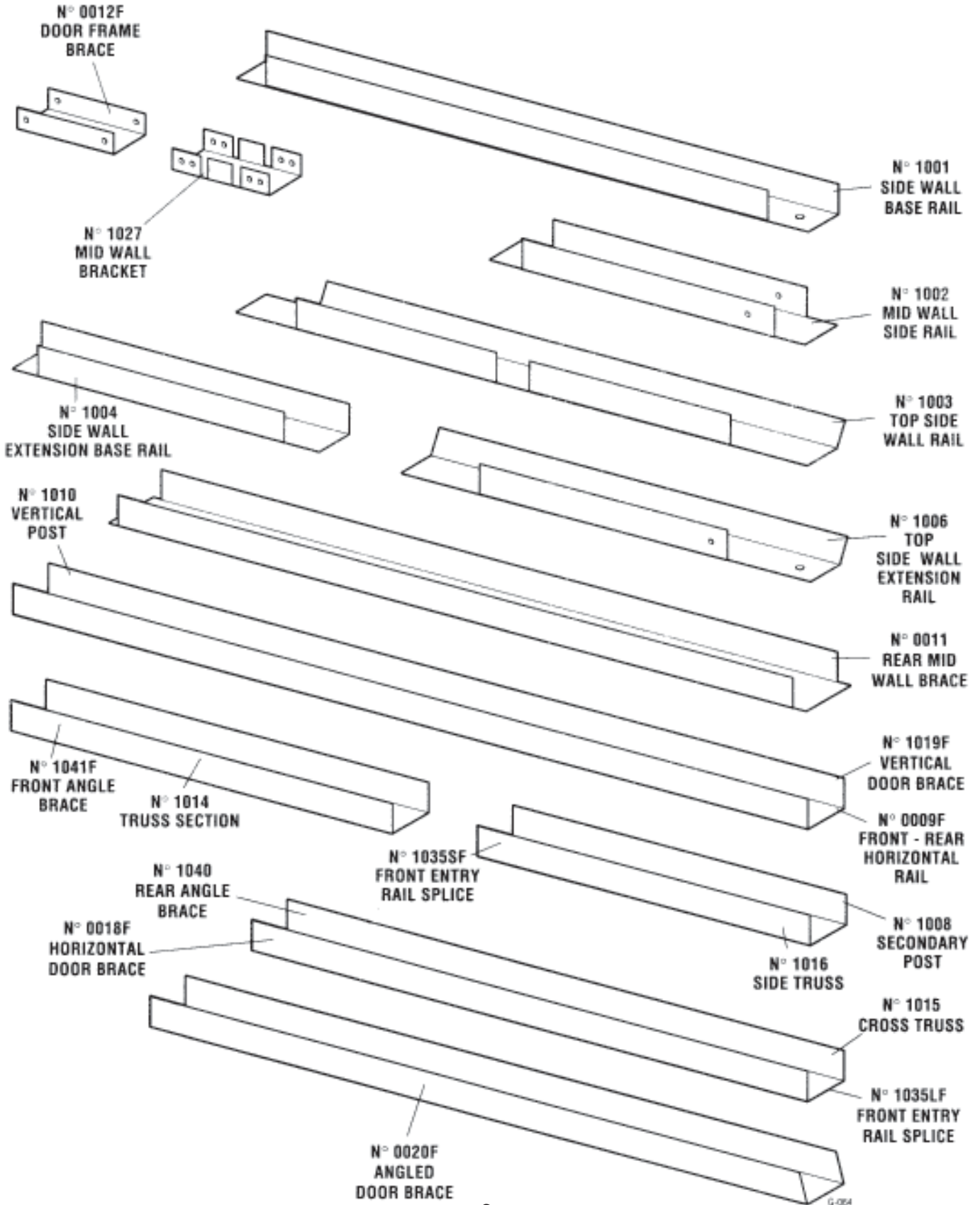

LARGER PARTS

NOTE: DRAWINGS ARE NOT TO SCALE, BUT ARE DESIGNED TO SHOW CROSS SECTIONS AND GENERAL CONFIGURATION TO AID IDENTIFICATION

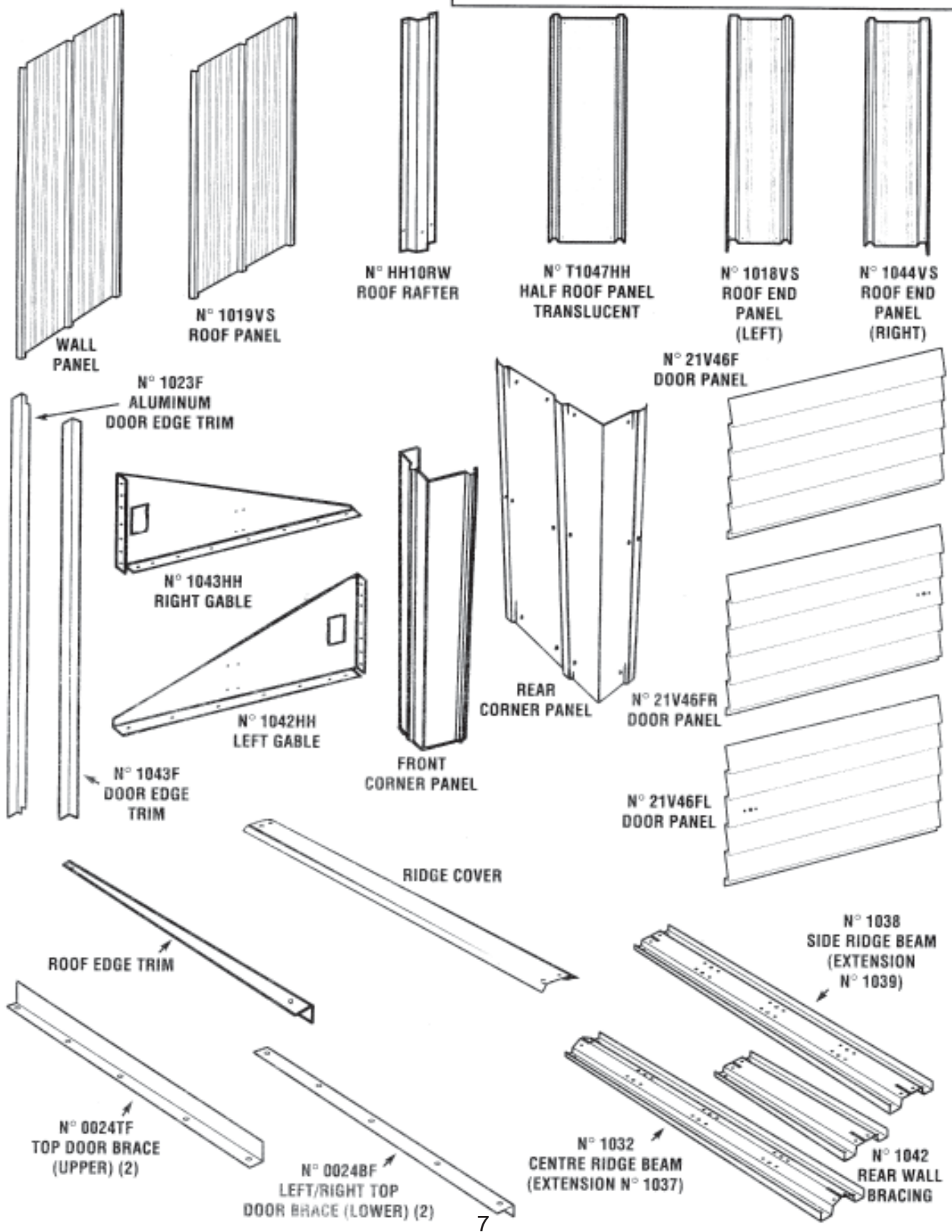

PARTS LISTINGS

IMPORTANT. WHEN ORDERING PARTS PLEASE PROVIDE THE NUMBER STAMPED ON THE SURFACE OF GALVANIZED PARTS. IN THE CASE OF WALL, CORNER AND ROOF PANELS, PLEASE PROVIDE THE MODEL NUMBER, COLOUR AND SIZE OF WALL PANELS. TO ORDER PARTS PLEASE USE ORDER FORM ON PAGE 41.

PART #	PART NAME	(1.52m) 5' MASTER CARTON	(1.22m) 4' MODULE	(1.83m) 6' MODULE	(2.44m) 8' MODULE
1001	SIDE WALL BASE RAIL	2	2	2	4
1002	MIDWALL SIDE RAIL	4	4	6	8
1003	TOP SIDE WALL RAIL	2	2	2	4
1004	SIDE WALL EXTENSION BASE RAIL	-	-	2	-
1006	TOP SIDE WALL EXTENSION RAIL	-	-	2	-
0009F	FRONT/REAR WALL HORIZONTAL RAIL	6	-	-	-
1040	REAR ANGLE BRACE	2	-	-	-
1010	VERTICAL POST	13	4	6	8
1008	SECONDARY POST	2	4	6	8
1027	MIDWALL BRACKET	2	4	6	8
0011	REAR MIDWALL BRACE	2	-	-	-
1042	REAR WALL BRACING	1	-	-	-
0012F	ENTRY FRAME SIDE BRACE	6	-	-	-
1041F	FRONT ANGLE BRACE	4	-	-	-
1014	TRUSS TOP SECTION	6	4	6	8
1015	CROSS TRUSS	3	2	3	4
1016	TRUSS SIDE SECTION	6	4	6	8
1035LF	FRONT ENTRY RAIL SPLICE. (LARGE)	1	-	-	-
1035SF	FRONT ENTRY RAIL SPLICE. (SMALL)	1	-	-	-
1029	TRUSS CENTRE BRACKET	5	4	6	8
1029B	REAR CENTRE BRACKET	2	-	-	-
1031	TRUSS ANGLE BRACKET	12	8	12	16
#44	REINFORCEMENT TRUSS PLATE	12	8	12	16
1032	CENTRE RIDGE BEAM	1	1	1	2
1037	CENTRE RIDGE BEAM EXTENSION	-	-	1	-
1038	SIDE RIDGE BEAM	2	2	2	4
1039	SIDE RIDGE BEAM EXTENSION	-	-	2	-
#1	VERTICAL POST LINK	2	-	-	-
0018F	HORIZONTAL DOOR BRACE	6	-	-	-
1019F	VERTICAL DOOR POST	4	-	-	-
0020F	ANGLED DOOR BRACE	4	-	-	-
21V46F	DOOR PANEL	4	-	-	-
21V46FR	DOOR PANEL (CENTRE RIGHT PANEL)	1	-	-	-
21V46FL	DOOR PANEL (CENTRE LEFT PANEL)	1	-	-	-
1023F	ALUMINUM DOOR EDGE TRIM	1	-	-	-
1043F	DOOR EDGE TRIM	4	-	-	-
0024TF	DOOR TOP BRACE	2	-	-	-
0024BF	LEFT & RIGHT TOP DOOR BRACE (LOWER)	2	-	-	-
1033	DOOR FRAME ANCHORING BRACKET	2	-	-	-
1042HH	LEFT GABLE	2	-	-	-
1043HH	RIGHT GABLE	2	-	-	-
1019VS	ROOF PANEL	2	4	6	8
T1047HH	HALF PANEL (TRANSLUCENT)	4	-	-	-
1044VS	ROOF END PANEL (RIGHT)	2	-	-	-
1018VS	ROOF END PANEL (LEFT)	2	-	-	-
HH10RW	ROOF RAFTER	2	4	6	8
#2	RIDGE COVER MOUNTING BRACKETS	1	1	2	2
520H	RIDGE COVER	1	-	-	-
920H	RIDGE COVER	-	1	-	2
GA20	RIDGE COVER	-	-	1	-
541H	ROOF EDGE TRIM	2	2	-	4
GA41	ROOF EDGE TRIM	-	-	2	-
5H76MWH	REAR CORNER PANEL	2	-	-	-
L5G76MWH	LEFT FRONT CORNER PANEL	1	-	-	-

CONTINUED ON NEXT PAGE

PART#	PARTNAME	(1.52m) 5' MASTER CARTON	(1.22m) 4' MODULE	(1.83m) 6' MODULE	(2.44m) 8' MODULE
R5G76MWH	RIGHT FRONT CORNER PANEL	1	-	-	-
33	LEFT/RIGHT GABLE BRACKET	16	-	-	-
21H76WH	WALL PANEL	7	4	6	8
49H	RIDGE COVER END CAPS	2	-	-	-
40H	ALUMINUM WEATHER SEAL TAPE	1	1	-	-
50H	ALUMINUM WEATHER SEAL TAPE	-	-	1	1
P61	PLASTIC WASHERS (SHEET OF 64)	5	2	3	4
BT1A	WEATHER SEAL FOAM	2	-	-	-
13-100	LOUVER	2	-	-	-
19-000F	DOOR ALUMINUM EXTRUSION	2	-	-	-
19-001F	DOOR RUBBER INSERT FOR EXTRUSION	2	-	-	-
4L	HINGE	4	-	-	-
DH14L	LEFT DOOR HANDLE	1	-	-	-
DH14R	RIGHT DOOR HANDLE	1	-	-	-
C14	PLASTIC DOOR HANDLE SPACER	4	-	-	-
C15	PLASTIC DOOR HANDLE SPACER	2	-	-	-
12-220	TINNERMAN NUT	2	-	-	-
19-020	CANE BAR BRACKET - BENT	2	-	-	-
19-021	CANE BAR BRACKET	2	-	-	-
19-023	CANE BAR ASSEMBLY	2	-	-	-
19-030	HANDLE COVER	2	-	-	-
13-007	EMBLEM	2	-	-	-
80	TAPE FOR EMBLEM	2	-	-	-
12-005P	HARDWARE PACK	1	-	-	-
12-004P	HARDWARE PACK	-	1	-	-
12-006P	HARDWARE PACK	-	-	1	-
12-008P	HARDWARE PACK	-	-	-	1
	INSTRUCTION MANUAL	1	-	-	-

ASSEMBLY DIAGRAM

For reference only!
Please use instructions on the following
pages to erect building.

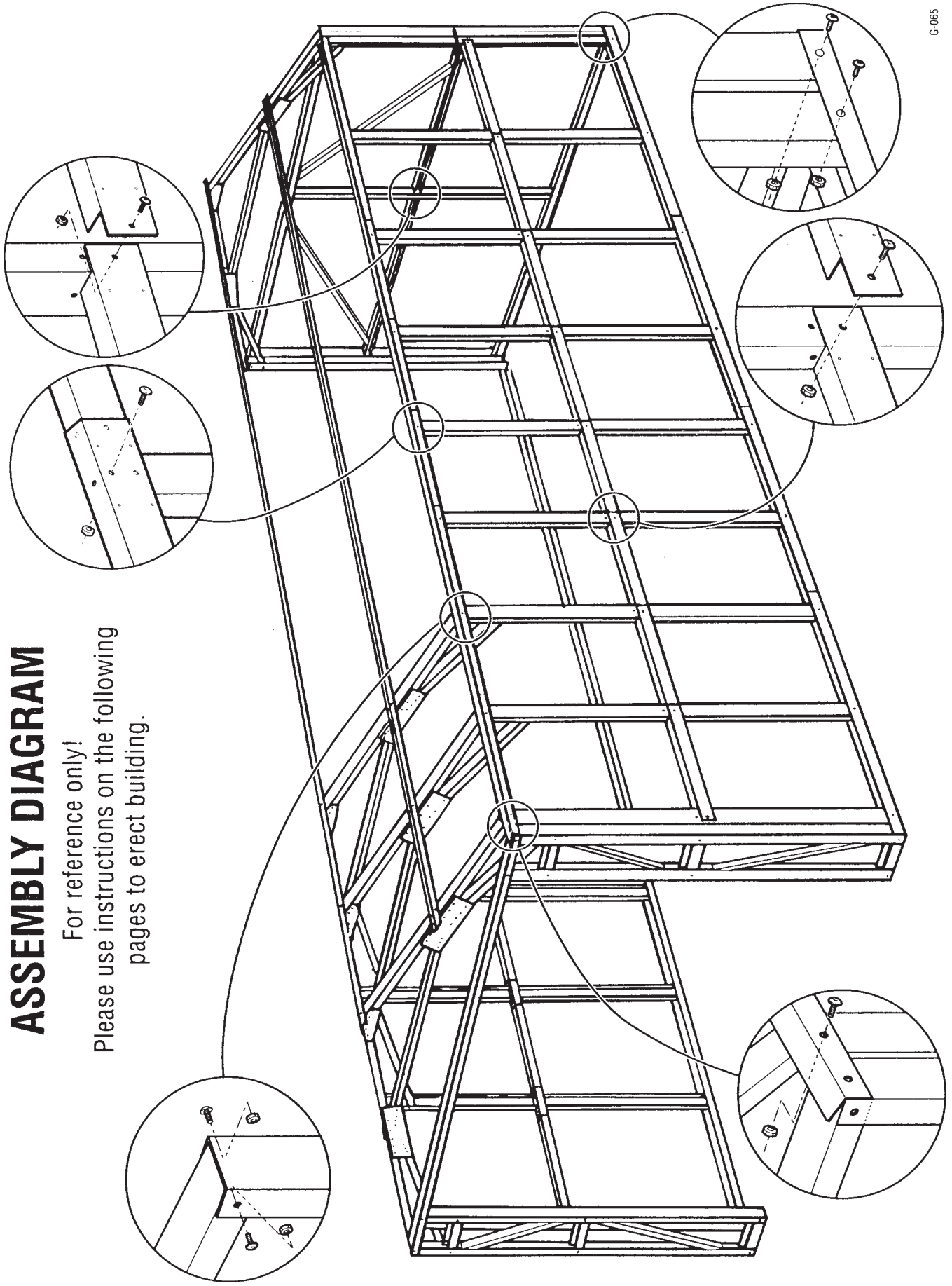

1

TRUSS AND POST ASSEMBLY (sub-assembly)

To assemble each complete Truss and Post required for your model of building you will require the following components: (2) #1014, (1) #1015, (4) #1031, (2) #1016, (2) #1029, (2) #1010, (2) #1008 and (4) #44. See chart for the total number of Truss and Post assemblies required by your particular model of building. Refer to Fig. 1 on page 12.

- 1.1 Working on a level surface, position the two (2) #1014 Truss Sections end to end and angled downwards so they form an inverted "V". Position a #1029 Truss Centre Bracket on the centre join made by the two #1014 Truss Sections. Secure #1029 bracket to both #1014 Truss Sections using two (2) bolts, nuts and self tapping screws through the fixing holes in the #1029 Bracket.
- 1.2 Position the two (2) #1031 Truss Angle Brackets at their required positions approximately halfway along the length of the #1014 Truss Sections. Note from the illustration the required position and direction of the Truss Angle Brackets fixing holes. Using six (6) self tapping screws, attach the Truss Angle Brackets to the #1014 Truss Sections using fixing holes provided.
- 1.3 Position the #1015 Cross Truss in position underneath the two (2) #1031 Truss Angle Brackets. Secure Cross Truss to Truss Angle Bracket using self tapping screws, bolts and nuts where required.
- 1.4 Position a #1016 Side Truss under the #1031 Truss Angle Bracket. Attach using self tapping screws.
- 1.5 Attach the #1029 Bracket and the #1031 Angle Brackets on the opposite side of the assembly using the above instructions.

1.6 Position a #1010 Vertical Post on either side of the Truss assembly as shown in the illustration. Ensure the Truss sections are positioned inside the channel section of the Vertical Posts. Using two (2) bolts and nuts, per join, attach a Vertical Post to each arm of the Truss Assembly, using the two uppermost side fixing holes of each Vertical Post for these joins.

1.7 Fasten a #44 Reinforcement Truss Plate into position on the Vertical Post, as shown below, using a bolt and nut. Complete the installation using a self tapping screw in the vacant fixing hole. Repeat instruction for the other side of the Vertical Post.

INSTALLATION NOTE... The first Truss and Post assembly used in the construction, (installed in the 2nd from the rear position) is required to have a #1029 bracket replaced with a special #1029B bracket. Later instructions will show how this #1029B bracket is to be used. Refer to Fig. 1a on page 12.

1.8 Position a #1008 Secondary Post as shown in the illustration so that it forms a "box" section with the Vertical Post. Attach each Secondary Post using ten (10) self tapping screws through the side fixing holes provided.

As previously mentioned, the Truss Assembly which is to be located 2nd from the rear of the building is to be fitted with one #1029 Bracket facing towards the front of the building and one of the #1029B Brackets facing the rear of the building. This #1029B Bracket will marry with the other #1029B Bracket which will be fitted to the Rear Wall Frame (See Fig. 1a). Details of this Brackets location will be given later in these instructions.

INSTALLATION NOTE.. The truss assemblies used at the entrance and rear of the building do not require the #1008 Secondary Post to be attached.

#44
REINFORCEMENT
TRUSS PLATE

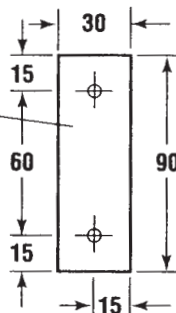

ALL DIMENSIONS IN MILLIMETRES (MM)

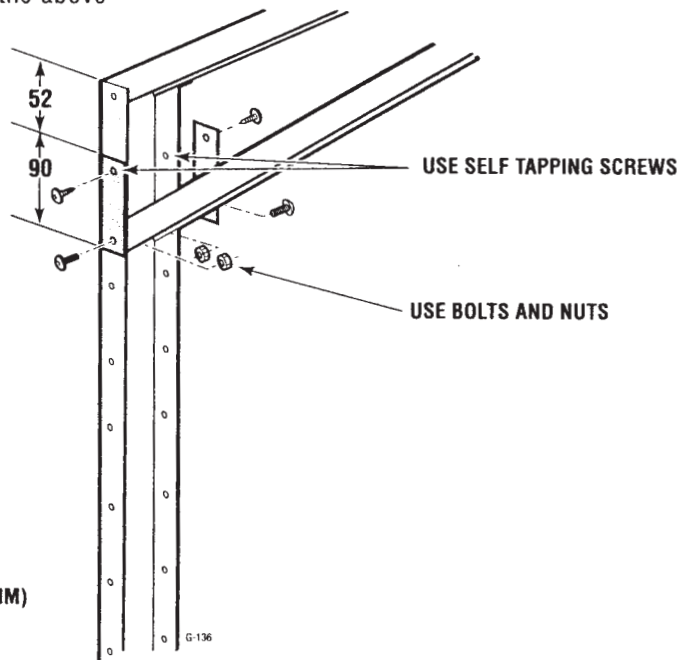

"Fig. 1"

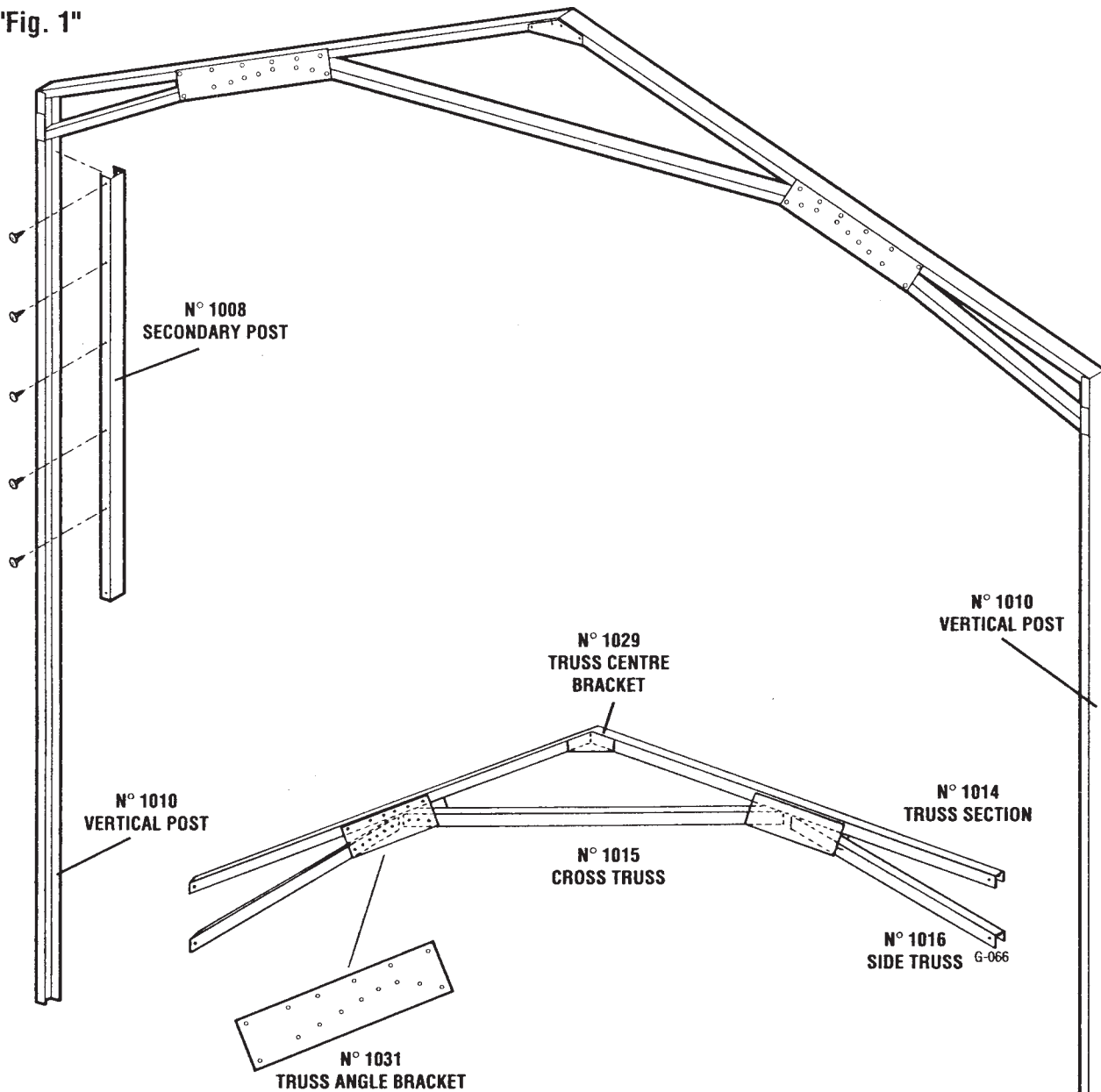

Model GA105 = 3 trusses
Model GA109 = 5 trusses
Model GA1011 = 6 trusses
Model GA1013 = 7 trusses
Model GA1015 = 8 trusses
Model GA1017 = 9 trusses
Model GA1019 = 10 trusses
Model GA1021 = 11 trusses
Model GA1023 = 12 trusses
Model GA1025 = 13 trusses
Model GA1027 = 14 trusses
Model GA1029 = 15 trusses
Model GA1031 = 16 trusses
Model GA1033 = 17 trusses
Model GA1035 = 18 trusses

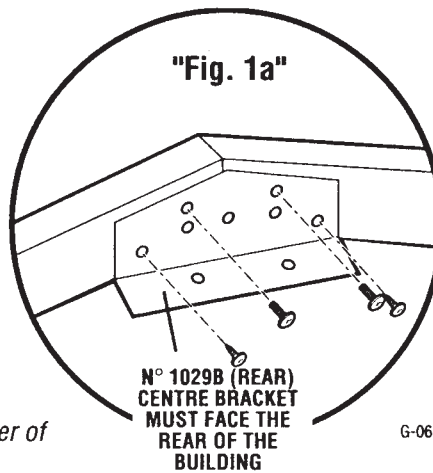

The number of trusses will vary accordingly to the number of extension modules purchased. Use this table as a guide.

G-067

G-068

2

REAR WALL FRAME ASSEMBLY

To assemble the Rear Wall Frame you will require the following components: (3) #1010, (4) #0009F, (2) #0011, (2) #1040, and (1) #1029B. Refer to Fig. 2 on page 14.

- 2.1 Working on a level surface, overlap two (2) #0009F Horizontal Rails. **INSTALLATION NOTE...** To locate the amount of overlap required in the two #0009F rails, overlap both 6mm (1/4") holes in it's inner channel section. See Fig. 2c on page 14.
- 2.2 Position a #1010 Vertical Post (90 degrees to the Base Rail sections) at the centre join of the two #0009F sections. **INSTALLATION NOTE...** The inner channel section of the Vertical Post is required to face either side of what will be the finished Rear Wall Frame.
- 2.3 Attach the two (2) #0009F Horizontal Rails to the centre #1010 Vertical Post of the Frame using two (2) bolts and nuts. See Fig 2c.
- 2.4 Position a #1010 Vertical Post at each end of the #0009F assembly. Attach each post to the #0009F Horizontal Rails using two (2) bolts and nuts for each of the joints. See Fig. 2.
- 2.5 Select two (2) more #0009F Horizontal Rails, overlap the Horizontal Rails in the same manner as described in a previous step. Position the two #0009F sections across the top of the three (3) Vertical Posts so a rectangular frame is formed .
- 2.6 Using two (2) bolts and nuts for each join, attach the Vertical Posts to the Horizontal Rails.
- 2.7 Position a #1029B Truss Centre Bracket (rear) on the inside surface of the frame at the junction of the two #0009F Horizontal Rails and the centre #1010 Vertical Post. **INSTALLATION NOTE...** This #1029B Bracket will face the #1029B Bracket on the second from rear Truss assembly. Secure the #1029B Bracket, centre Vertical Post and the Horizontal rails together using a bolt, nut and two (2) self tapping screws. The remaining (rear) fixing hole of the centre Vertical Post is required to be attached to the #0009F Horizontal Rails using a single bolt and nut. See Fig. 2b on page 14.
- 2.8 Position two (2) #0011 Rear Midwall Braces between the two outside Vertical Posts and the Centre Vertical Post at the Midwall height position. **IMPORTANT INSTALLATION NOTE...** Attach Midwall Rails to Vertical posts using the lower 6mm (1/4") fixing holes at the midwall height position. Attach the Midwall Rails using a single bolt and nut for each join. See Fig 2a on page 14.
- 2.9 Position a #1040 Rear Angle Brace on the inside surface of each side Vertical Post and Horizontal Rail as shown in the illustration. Using two (2) self tapping screws for each join, secure Rear Angle Braces to the frame assembly. Repeat instruction to attach the opposite side Rear Angle Bracket.

Ensure that all fixing bolts and screws used in the assembly are tight.

"Fig. 2a"

VIEWED FROM REAR

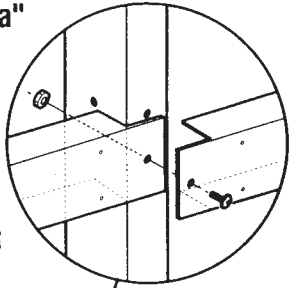

N° 1029B TRUSS CENTRE BRACKET

"Fig. 2b"

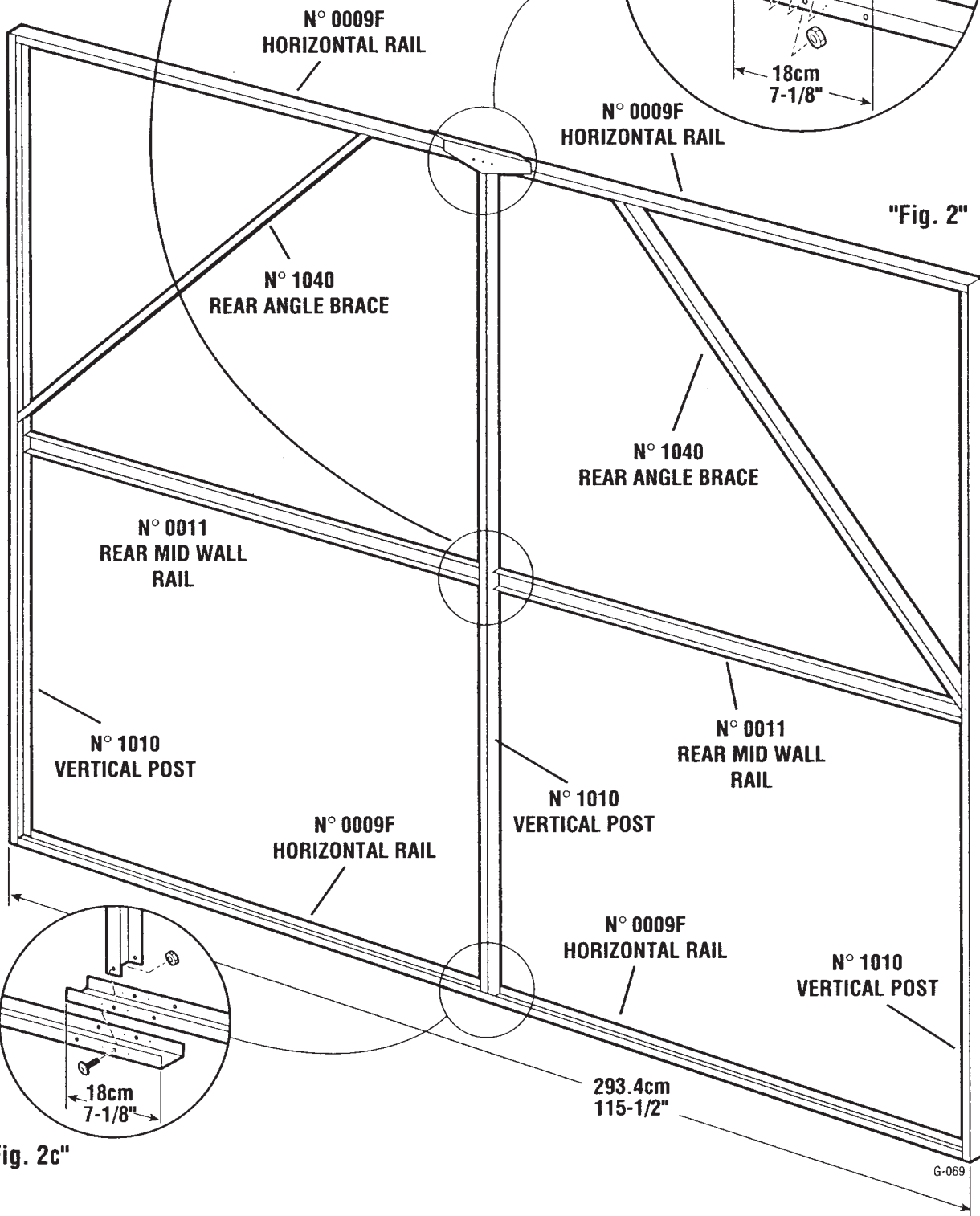
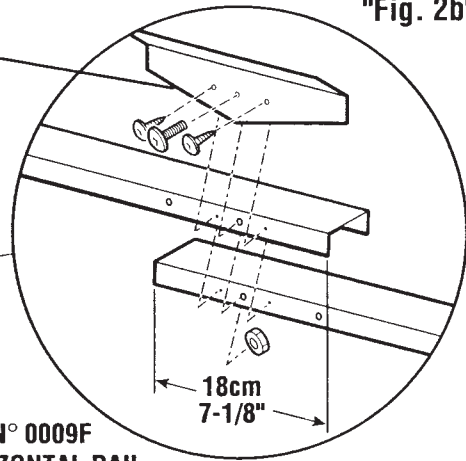

"Fig. 2"

"Fig. 2c"

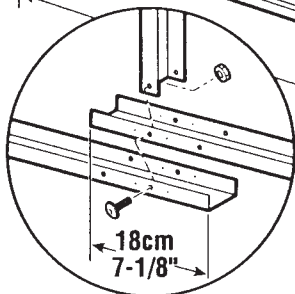

3

FRONT ENTRY FRAME ASSEMBLY (sub-assembly)

To assemble the Front Entry Frame you will require the following components: (4) #1010, (2) #0009F, (6) #0012F, (4) #1041F, (1) #1035SF, (1) #1035LF, (1) #L5G76MWH, and (1) #R5G76MWH. **INSTALLATION NOTE...** While assembling the Front Entry Frame it is necessary to secure the Left and Right Front Corner Panels #L5G76MWH and #R5G76MWH into place at the same time. Refer to Fig. 4b on page 18.

FRONT SIDE ENTRY FRAME ASSEMBLY (2 required)

- 3.1 Working on a level surface position two (2) #1010 Vertical Posts approximately 30.5cm (12") apart.
- 3.2 Select a #0012F Entry Frame Brace. Ensure that the lower edge of the channel section is positioned towards what will be the foundation of the building. (See Fig. 3 for details.) Position #0012F Entry Frame Side Brace between the lower fixing holes of each #1010 Vertical Post. **INSTALLATION NOTE...** It is necessary to attach the lower and mid #0012F Braces on only one side of the Vertical Posts. (This side will later be used and referred to as the inside surface of the Entry Frame.)
- 3.3 Position the mid #0012F Entry Frame Brace and a #1041F Front Entry Angle Brace over each other so that their inner channel sections and the 6mm (1/4") fixing holes unite with each other at one end only. See Fig. 3.

INSTALLATION NOTE... The channel section of the #0012F Brace is required to face downwards when the Brace is placed across the upper two fixing holes in the centre of the Vertical Posts. These two fixing holes are located just above the mid-height position of each post. Attach the mid #0012F Brace and #1041F Angle Brace to the mid inside channel of the Vertical Posts using a bolt and nut on the inside surface of the frame only.

- 3.4 Position a third #0012F Entry Frame Brace across the 2nd 6mm (1/4") fixing holes from the top. Position the free end of the upper #1041F Brace on the inside channel of the #0012F Brace. Secure the Entry Frame Brace and Entry Frame Angle Brace into position on the 6mm (1/4") fixing holes provided on both sides of the Vertical Posts. Using two (2) self tapping screws and two (2) bolts and nuts attach both braces to the Vertical Posts.

- 3.5 Position the lower #1041F Front Angle Brace into position on the inner channel of the Vertical Posts. (See Fig. 3.) Secure lower #1041F Entry Frame Angle Brace into position at the required fixing locations using two (2) self tapping screws at the lower end join and two (2) bolts and nuts for the upper join with the Vertical Post.

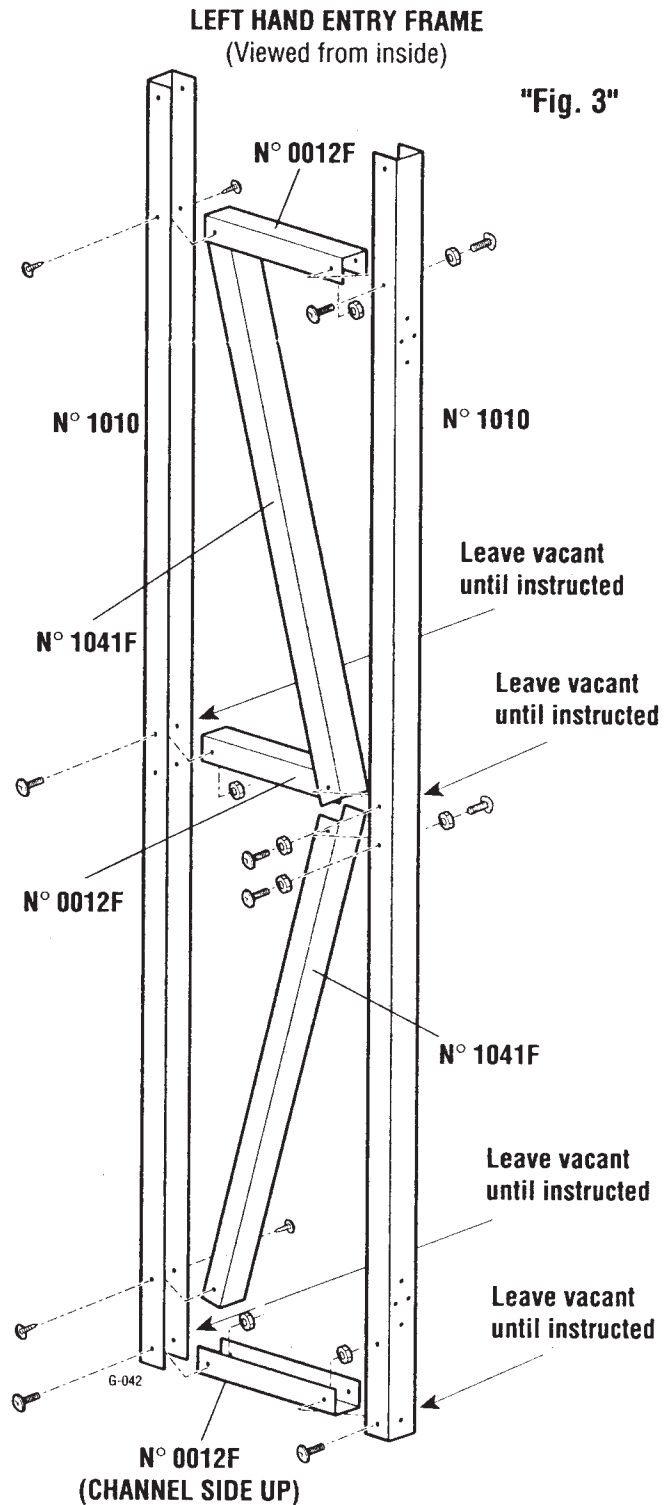

Assemble a second Side Entry Frame in the same manner as described above.

4

ENTRY FRAME HORIZONTAL RAIL ASSEMBLY

4.1 Working on a level surface, overlap two (2) #0009F sections. **INSTALLATION NOTE...** To locate the amount of overlap required in the two (2) #0009F rails, overlap both 6mm (1/4") holes in it's inner channel section. See Fig. 4a.

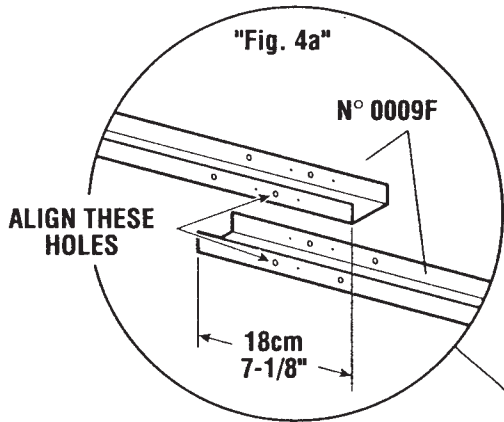

(DO NOT USE ANY FASTENERS AT THIS TIME.) The two components should measure a total length of 292.42cm (115 1/8"). Select the #1035LF component (a pre-painted component).

4.2 Place the #1035LF component over the two (2) #0009F sections forming a "box". (See Fig. 4.) Position the shorter pre-painted component #1035SF at the end of the #1035LF that contains the double set of side fixing holes. (See Fig. 4.) Using self tapping screws along each side of the two pre-painted components. Using all the fixing holes, attach all four components together so they form a rigid box section measuring 292.42cm (115 1/8") long.

4.3 Position the completed Entry Frame Horizontal Rail ensuring it's inner channel fits over the four #1010 Vertical Posts of two pre-assembled Front Entry Frames. **NOTE...** Only the inner fasteners should be used at this time. The outer fasteners will be used when fitting the Corner Panels.

ENTRY FRAME HORIZONTAL RAIL MUST BE TURNED OVER FOR FINAL ASSEMBLY ONTO FRONT ENTRY FRAMES.

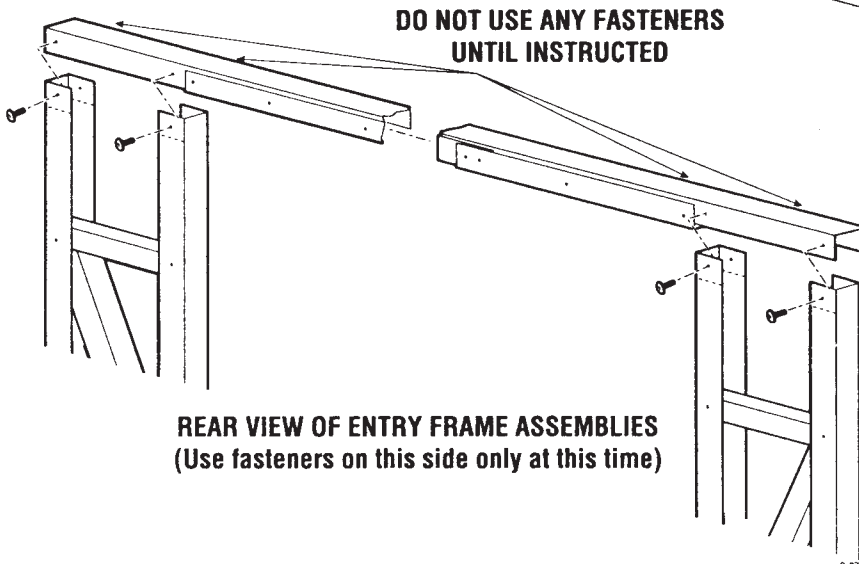
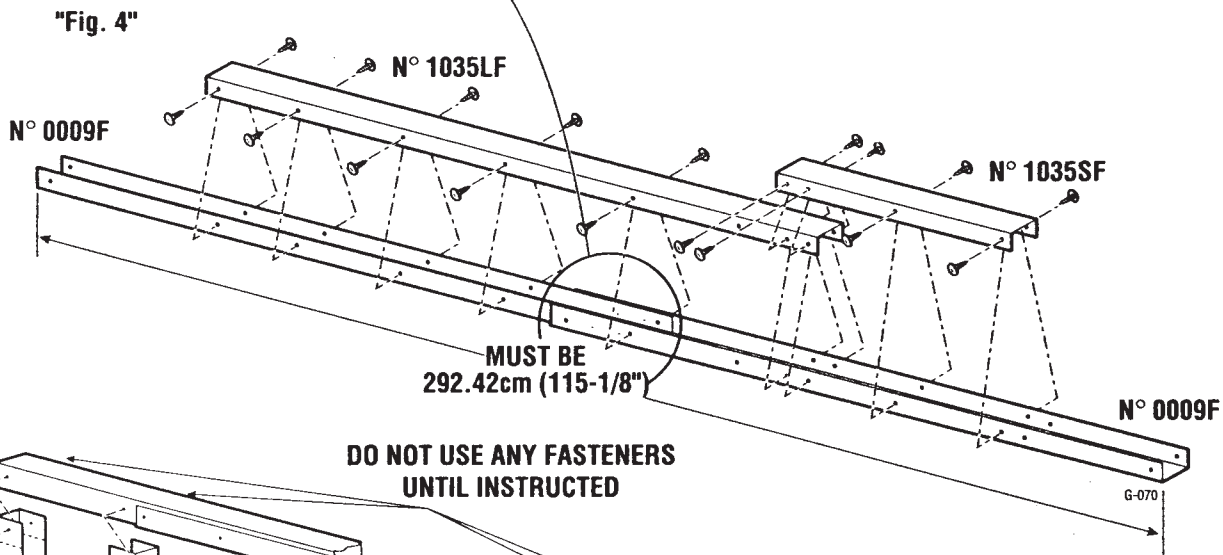

REAR VIEW OF ENTRY FRAME ASSEMBLIES
(Use fasteners on this side only at this time)

Attaching Front Corner Panels

- 4.4 From what will be the outside of the Entry Frame (i.e. the side without fasteners) position the #R5G76MWH Right Front Corner Panel. Attach Right Front Corner Panel to the Right Hand Front Entry Frame (viewed from inside building) using the six (6) vacant front fixing holes of each Entry Frame. **INSTALLATION NOTE...** These six (6) fasteners are required to pass through the Corner Panel and the top, mid and lower fixing holes of the Entry Frame. Refer to Fig. 4b on page 18.

IMPORTANT NOTE... All Midwall height fixing bolts are required to be fitted with a #P61 Plastic Washer.

- 4.5 Repeat the instruction above to install the #L5G76MWH Left Hand Corner Panel to the opposite Side Entry Frame assembly.

Attaching Door Hinges

W17

Select the four (4) Door Hinges #4L. **NOTE...** One leaf of each hinge has a slight offset in it, this leaf is required to be attached to the Door Frame and not on the Door.

- 4.6 Attach each Hinge using three (3) Countersunk bolts, nuts and 1.9cm (3/4") steel washers. Each countersunk bolt is required to pass first through the Hinge, and the Entry Frame where the 1.9cm (3/4") washer is fastened by a lock nut on the inside of the Entry Frame. (See Fig. 4c on page 18.)

Ensure that all fixing bolts and screws used in the assembly of the Entry Frame are tight.

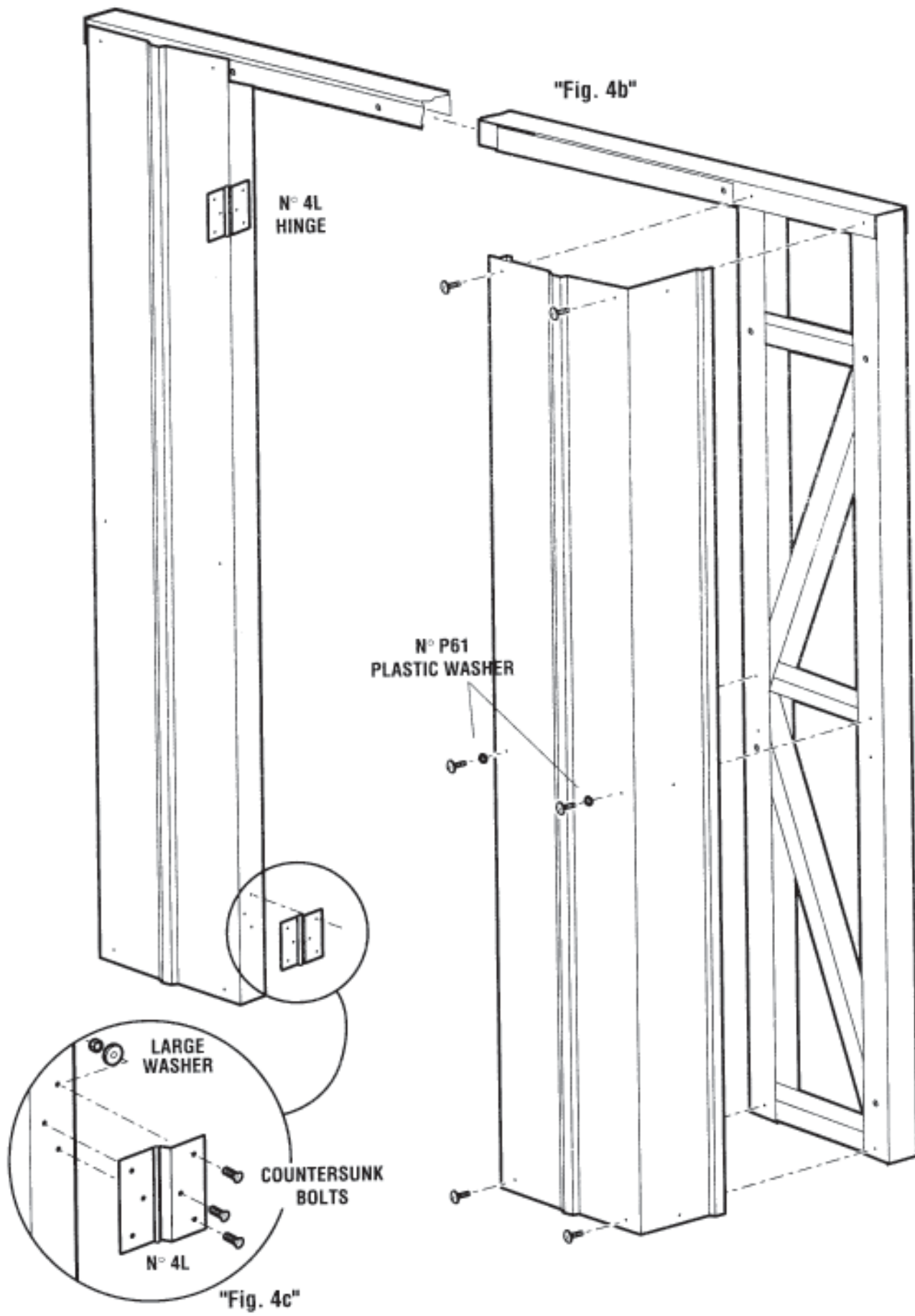

5

RIGHT-HAND DOOR ASSEMBLY

(Viewed from inside building)

To assemble a completed right-hand door select the following components:

- 2 Vertical Posts #1019F
- 3 Horizontal Door Braces #0018F
- 2 Angled Door Braces #0020F
- 1 Aluminum Extrusion #19-000F
- 1 Rubber Insert #19-001F
- 2 Door Panels #21V46F
- 1 Centre Door Panel #21V46FR
- 1 Left/Right Top Door Brace (lower section) # 0024BF
- 1 Top Door Brace (upper section) #0024TF
- 2 Door Edge Trims #1043F
- 1 Cane Bar Bracket (Bent) #19-020
- 1 Cane Bar Bracket #19-021
- 1 Cane Bar Assembly #19-023
- 1 Door Handle Kit #DH14R
- 2 Door Handle Spacers #C14
- 1 Door Handle Spacer #C15
- 2 Steel Washer #19-028
- 1 Tinnerman Nut #12-220

5.1 Position two (2) #1019F Vertical Door Posts approximately 1.5m (5') apart on a level surface, ensuring the inner channel sections of each Post face each other. Using Figure 5 as a guide, position three (3) #0018F Horizontal Door Braces and two (2) #0020F Angled Door Braces between the Vertical Door Posts. Using Bolts and Nuts attach the #0018F and #0020F Braces to the #1019F Vertical Door Posts. Fully tighten all bolts and nuts. Turn the completed frame over and fully tighten all bolts and nuts except the two fixing the bottom Horizontal Door Brace. These holes must be left vacant.

5.2 **Note...** the side of the Door Frame that is required to face outward should be facing up. Select the #19-021 Cane Bar Bracket. Using the illustration on page 21 as a guide, position the Cane Bar Bracket on the surface of the lower Horizontal Door Brace. Position Aluminum Extrusion #19-000F against the lower Horizontal Door Brace as shown in the illustration. Position lower Door Panel #21V26F onto the Door Frame so that the upper section of the Aluminum Extrusion, containing the fixing holes, is covered by the lower Door Panel. The edge of the Bracket must be between the Horizontal Brace and the lip of the Aluminum Extrusion. Fasten with Bolts and Nuts. Using three (3) Bolts and Nuts, placed through the three fixing holes in the Door Panel and Aluminum Extrusion, attach both components to the lower Horizontal Door Brace. Use self tapping screws in the centre holes on the outer edges of the panel. (See Figure 5).

"Fig. 5"

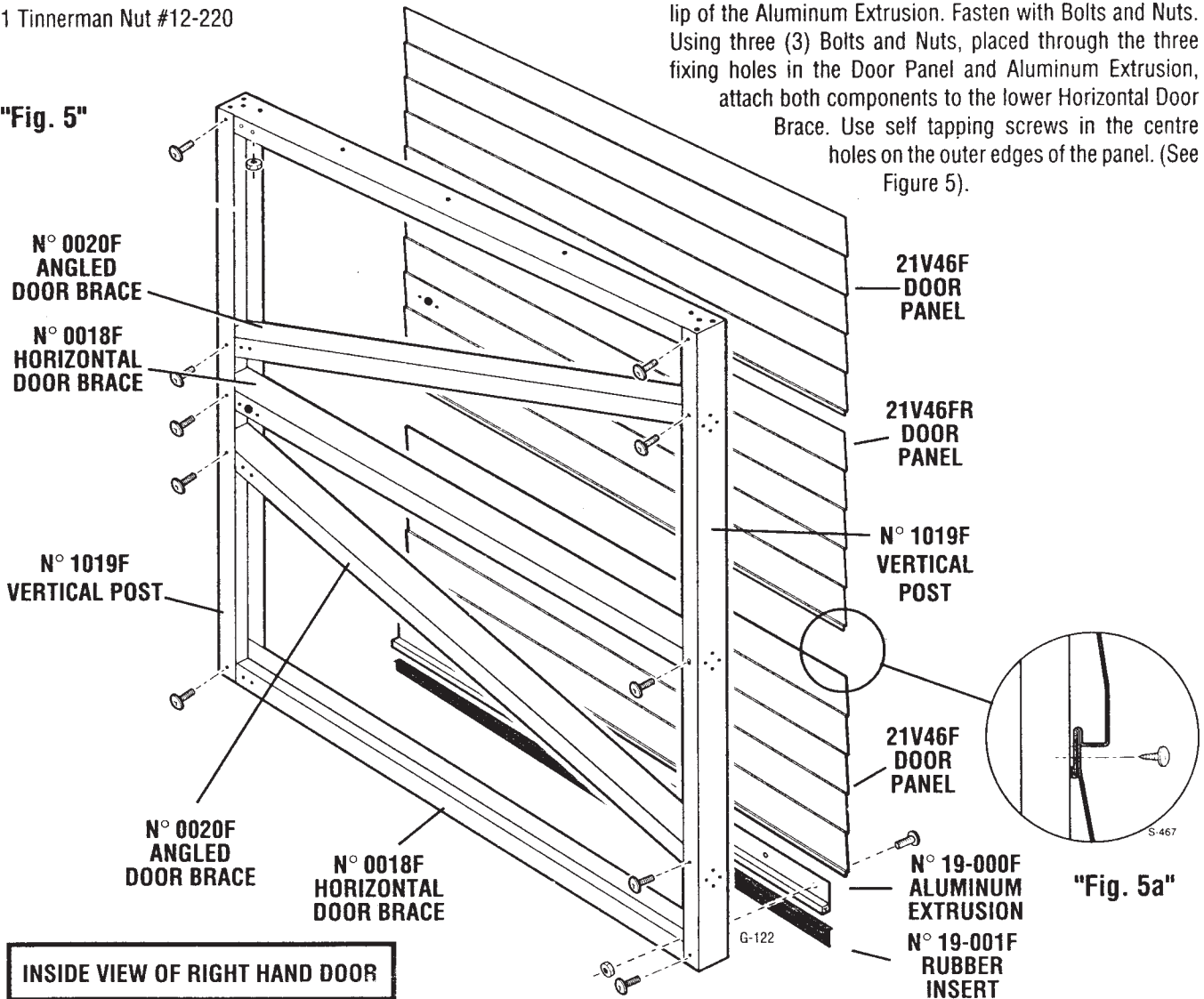

INSIDE VIEW OF RIGHT HAND DOOR

5.3 Position the #21V46FR Centre Door Panel, containing the Door Handle fixing holes, horizontally in the middle of the Door Frame as shown in the illustration. The holes for the handle must be on the Right side of the assembly. Fasten the centre and bottom edge positions with self tapping screws. **Note...** Door Panels are designed to interlock as shown in Fig. 5a.

5.4 Position a #21V46F Door Panel above the Centre Door Panel as shown in the illustration. Using Self Tapping Screws, attach the upper #21V46F Door Panel to the Door Frame through the outer edge fixing holes provided.

5.5 Select a #1043 Door Edge Trim section. Using the illustration on page 21 as a guide, align the fixing holes of the Door Edge Trim to the fixing holes provided on the side of the #1019F Vertical Post. Using Bolts and Nuts, attach Door Edge Trim to the Door Frame. Attach the opposite side #1043F Door Edge Trim in the same manner.

Note... The third hole from each end of the Door Edge Trim on the hinge side must be left vacant. These holes will be used later to mount the door hinges.

5.6 Turn the frame onto its long edge. Select a #1024TF Top Door Brace, a #0024BF Left/Right Top Door Brace and the #19-020 Cane Bar Bracket (Bent). Using the illustration on page 21 as a guide, align the fixing holes of the Top Door Brace and the Left/Right Top Door Brace. Position the Cane Bar Bracket (Bent) aligning the holes to the fixing holes provided in the Top Door Brace and the Left/Right Top Door Brace to those provided in the Door Frame.

5.7 Select outside #DH14R Door Handle and two (2) #C14 Door Handle Spacers. While sliding the square shaft of the Outside Door Handle through the larger hole of the Door Panel it is also necessary to slide two (2) #C14 Door Handle Spacers between the inside surface of the Centre Door Panel and the #0018F Central Door Brace. Using the two 3/4" #8-32 Phillips head bolts and #19-028 Steel Washers provided in the Hardware Pack attach the Door Handle to the centre Horizontal Brace. See Fig. 5b.

5.8 Select the following components: (1) #19-023 Cane Bar Assembly, (1) #C15 Door Handle Spacer and (1) #12-220 Tinnerman Nut. Slide the #C15 Door Handle Spacer onto the square section of the Door Handle Shaft protruding from the Horizontal Door Brace. See Fig. 5b.

5.9 Position the two (2) Cane Bars into the holes provided in the previously fitted top and bottom Cane Bar Brackets. **Important installation note...** Ensure the Door Handle is in a horizontal and open position before attempting the next instruction. Failure to correctly position the Door Handle could result in misalignment of the Cane Bars. The Cane Bars must not be fully extended at this time.

5.10 Align the square hole of the Cane Bar Assembly with the square shaft of the Door Handle. Slide the Cane Bar Assembly

onto the square shaft of the Door Handle. Test the installation to ensure that when turning the handle vertically the Cane Bars will be fully extended. When the installation is working properly press the #12-220 Tinnerman Nut onto the Door Handle square shaft, so that it locks the Cane Bar Assembly firmly onto the Door Handle shaft.

5.11 Slide a #19-030 Handle Cover onto the inner door handle.

5.12 Slide a section of #19-001F Rubber Insert into the channel provided in the #19-000F Aluminum Extrusion.

Your right-hand Door is now complete.

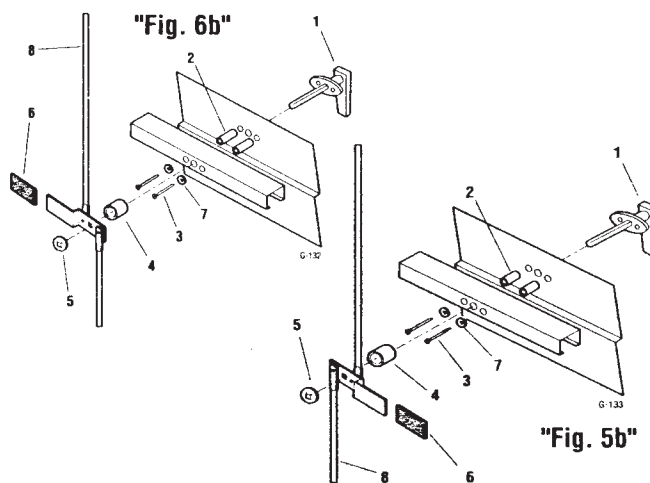

1	#DH14R Locking Handle	1
2	#C14 Lock Spacers	2
3	3/4" #8-32 Bolts	2
4	#C15 Spacer	1
5	#12-220 Tinnerman Nut	1
6	#19-030 Handle Cover	1
7	#19-028 Steel Washer	2
8	# Cane Bar Assembly	1

6

LEFT-HAND DOOR ASSEMBLY (Viewed from inside building)

To assemble a completed left-hand door select the following components:

- 2 Vertical Posts #1019F
- 3 Horizontal Door Braces #0018F
- 2 Angled Door Braces #0020F
- 1 Left/Right Top Door Brace (lower section) # 0024BF
- 1 Top Door Brace (upper section) #0024TF
- 1 Aluminum Extrusion #19-000F
- 1 Rubber Insert #19-001F
- 2 Door Panels #21V46F
- 1 Centre Door Panel #21V46FL
- 2 Door Edge Trims #1043F
- 1 Aluminum Door Edge Trim #1023F
- 1 Cane Bar Bracket (Bent) #19-020
- 1 Cane Bar Bracket #19-021

**INSIDE VIEW OF
RIGHT HAND DOOR**

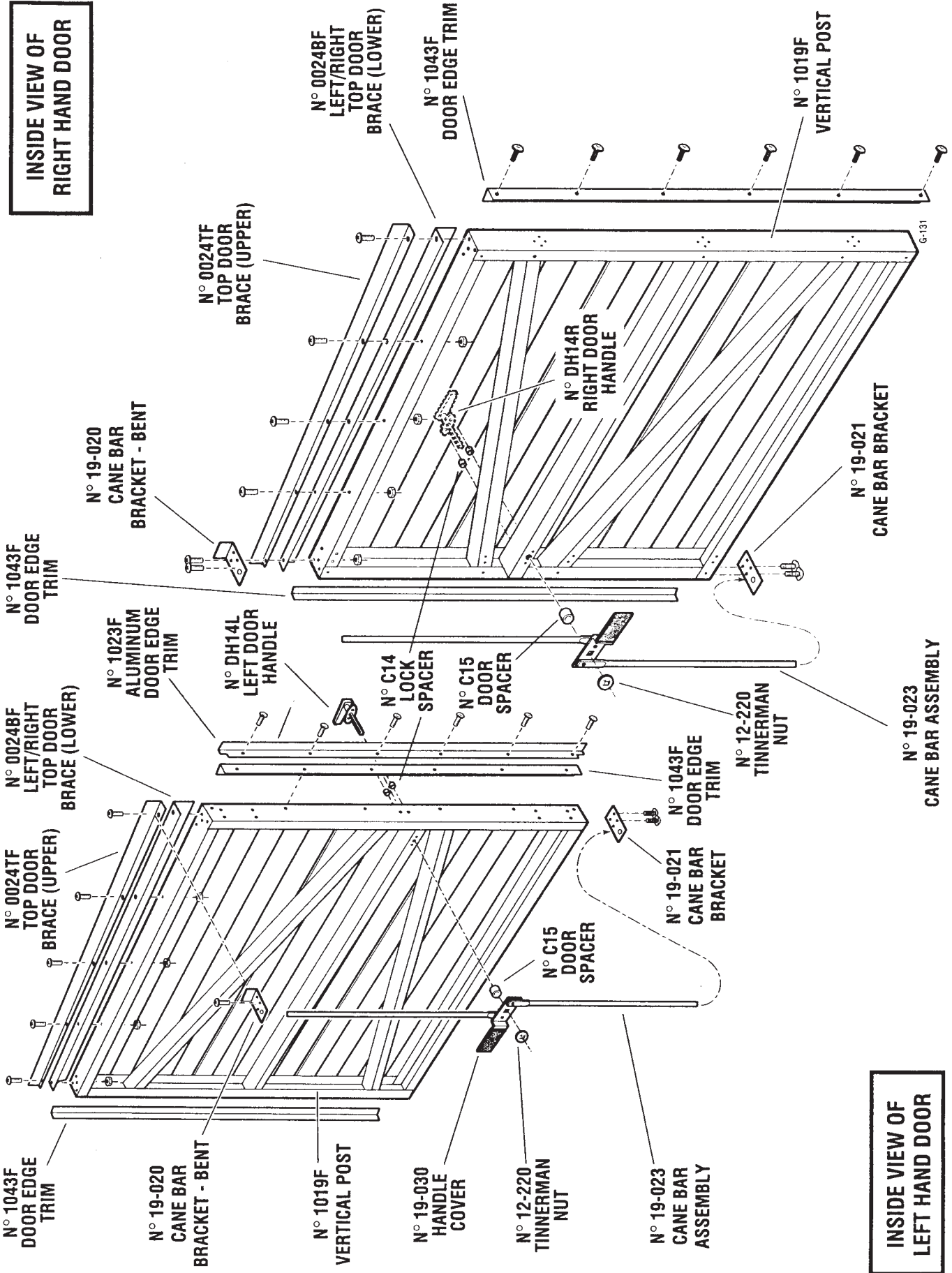

**INSIDE VIEW OF
LEFT HAND DOOR**

- 1 Cane Bar Assembly #19-023
- 1 Door Handle Kit #DH14L
- 2 Door Handle Spacer #C14
- 1 Door Handle Spacer #C15
- 2 Steel Washer #19-028
- 1 Tinnerman Nut #12-220

Assembly of the Left-Hand Door is identical to the Right-Hand Door instructions with the following exceptions: Centre Door Panel, Door Handle assembly and the addition of #1023F Aluminum Door Edge Trim. Refer to the instructions the Right-Hand Door except as follows:

- 6.1 Same as 5.1
- 6.2 Same as 5.2
- 6.3 Position the #21V46FL Centre Door Panel, containing the Door Handle fixing holes, horizontally in the middle of the Door Frame as shown in the illustration on page 21. The holes for the handle must be on the Left side of the assembly. Fasten the centre and bottom edge positions with self tapping screws. **Note**... Door Panels are designed to interlock as shown in Figure 6a.

- 6.4 Same as 5.4
- 6.5 Select a #1043 Door Edge Trim section and a #1023F Aluminum Door Edge Trim. Using the illustration on page 21 as a guide, align the fixing holes of the Door Edge Trims to the fixing holes provided on the side of the #1019F Vertical Post. Using Bolts and Nuts, attach Door Edge Trim to the Door Frame. Attach the opposite side #1043F Door Edge Trim in the same manner.

Note... The third hole from each end of the Door Edge Trim on the hinge side of the door must be left vacant. These holes will be used later to mount the door hinges. The #1023F Aluminum Door Edge Trim is designed to overlap the opposite door when in the closed position. If desired, this Trim may be fastened to the Right-Hand Door using the above instructions.

- 6.6 Same as 5.6
- 6.7 Select outside #DH14L Door Handle and two (2) #C14 Door Handle Spacers. While Sliding the square shaft of the Outside Door Handle through the larger hole of the Door Panel it is also necessary to slide two (2) #C14 Door Handle Spacers between the inside surface of the Centre Door Panel and the #0018F Central Door Brace. Using the two 3/4" #8-32 Phillips head bolts and #19-028 Steel Washers provided in the Hardware Pack attach the Door Handle to the centre Horizontal Brace. See Fig. 6b on page 20.

6.8 thru 6.12 Same as 5.8 thru 5.12.

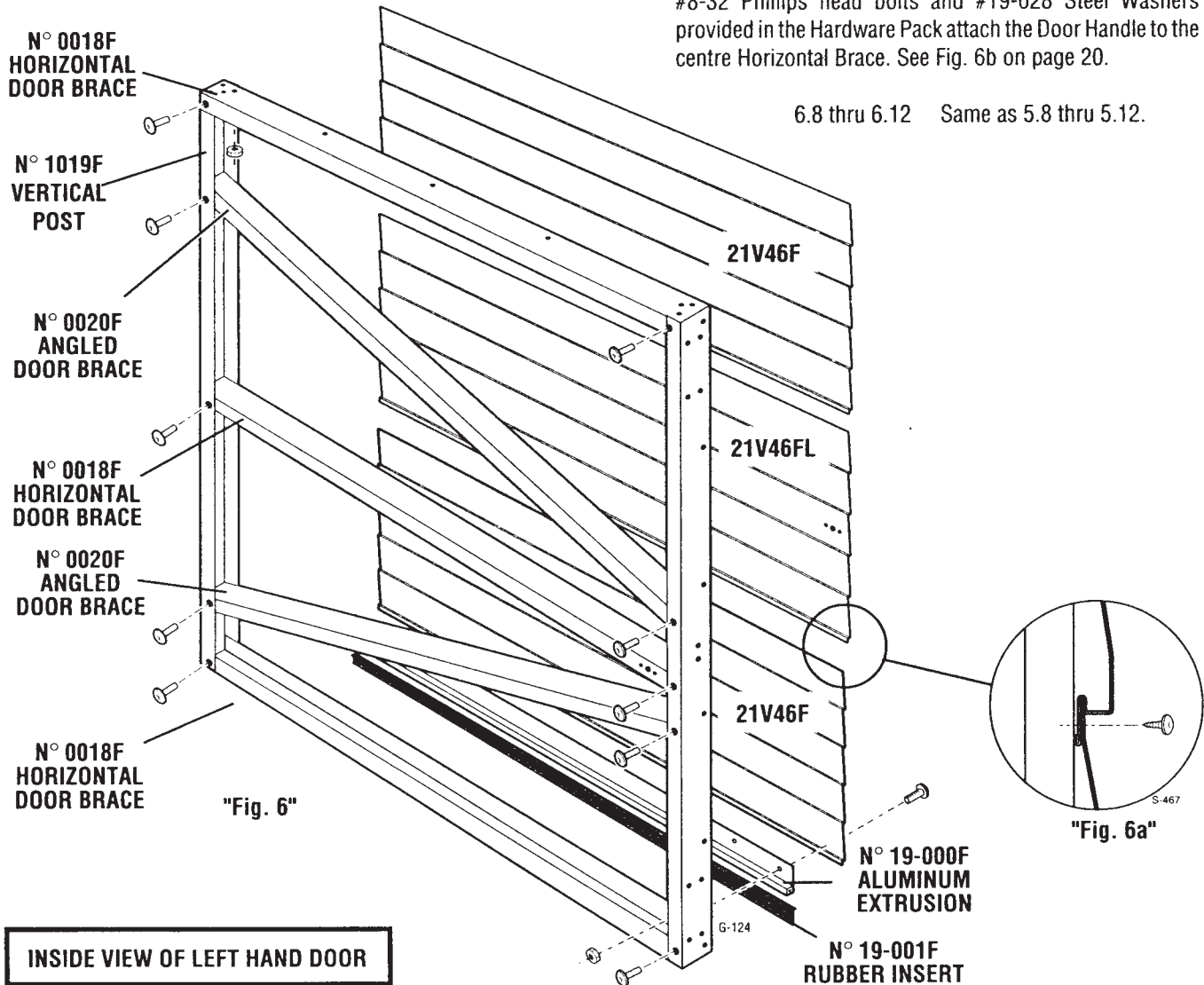

INSIDE VIEW OF LEFT HAND DOOR

6

MARKING THE FOUNDATION

Before starting the final assembly of the main structure, it is essential that chalklines are struck on the foundation base. This is to ensure squareness and provide guidelines for the rear and sidewall base rails. Below is a detail of how your foundation should be marked.

- 6.1 Measure the foundation width and mark the centre at each end.
- 6.2 Using a Chalkline strike a line between the two centre marks.
- 6.3 On each side of the centre line mark a position 146.7cm (57 3/4") from the centre line. Strike two Chalk Lines. (This

dimension, 293.4cm (115 1/2") is the actual outside dimensions between the left and right base rails.)

- 6.4 At the rear left or right hand side of the foundation, measure a distance of 15.2cm (6") along one of the previously marked chalk lines and mark this point.
- 6.5 Using the chalkline and a large set square, make a chalkline directly across the foundation which is exactly 90° to the previously struck side chalk lines.

THESE CHALK LINES WILL ASSIST YOU IN KEEPING THE BUILDING IN THE EXACT LOCATION IT IS TO BE ANCHORED. AS EACH BASE RAIL COMPONENT IS POSITIONED DURING THE FINAL ASSEMBLY YOU ARE ADVISED TO USE THESE CHALK LINES AS A GUIDE.

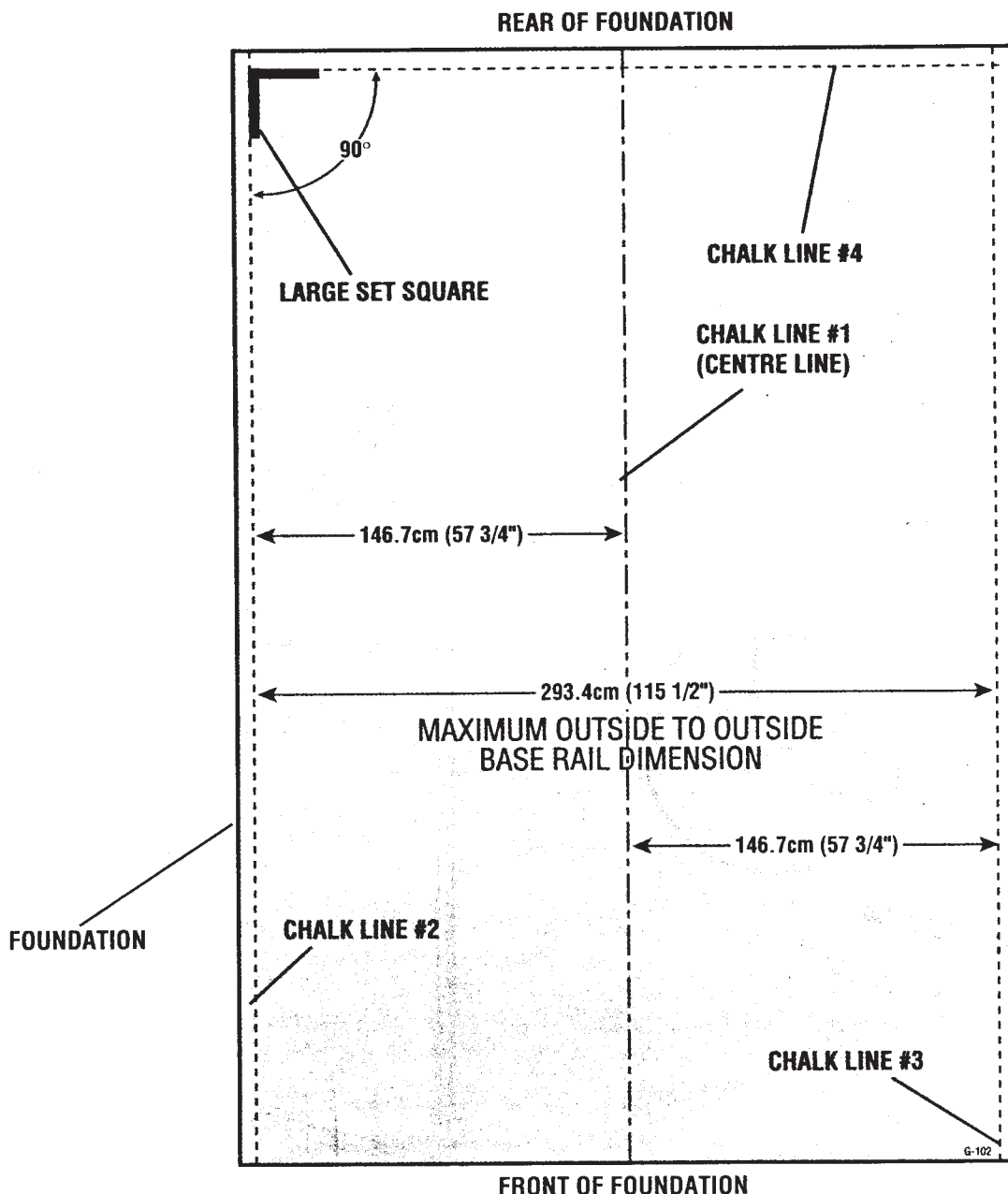

7

ASSEMBLY OF THE BUILDINGS MAIN STRUCTURE

- 7.1 Select two (2) #1001 Base Rails. **INSTALLATION NOTE...** The direction of the notched cutout in each Base Rail must face towards the inside of the foundation. (See illustration below.)
- 7.2 Position a Base Rail on the left hand side chalkline, the end of this Base Rail is to be placed at the junction of the side and rear chalkline.
- 7.3 Position the second Base Rail on the opposite right hand side chalkline, again with the end of the Base Rail on the junction of the two chalklines.

IT IS IMPORTANT FOR THE NEXT STEP THAT YOU SELECT THE TRUSS ASSEMBLY CONTAINING THE SPECIAL #1029B BRACKET.

- 7.4 Position the Truss Assembly, with it's #1029B Bracket facing towards the rear of the of the foundation. Position the Vertical Posts on the centre fixing holes of the two Base Rails that have been positioned on each side of the foundation. (This Truss will later be the second Truss assembly from the rear of the building).
- 7.5 Attach the two Vertical Posts of the Truss assembly to the outside fixing holes of both Base Rails so that the junction of the Vertical Post and Base Rail forms an inverted "T" shape. Tighten the fixing bolt at the base of each Vertical Post. (See illustration below)

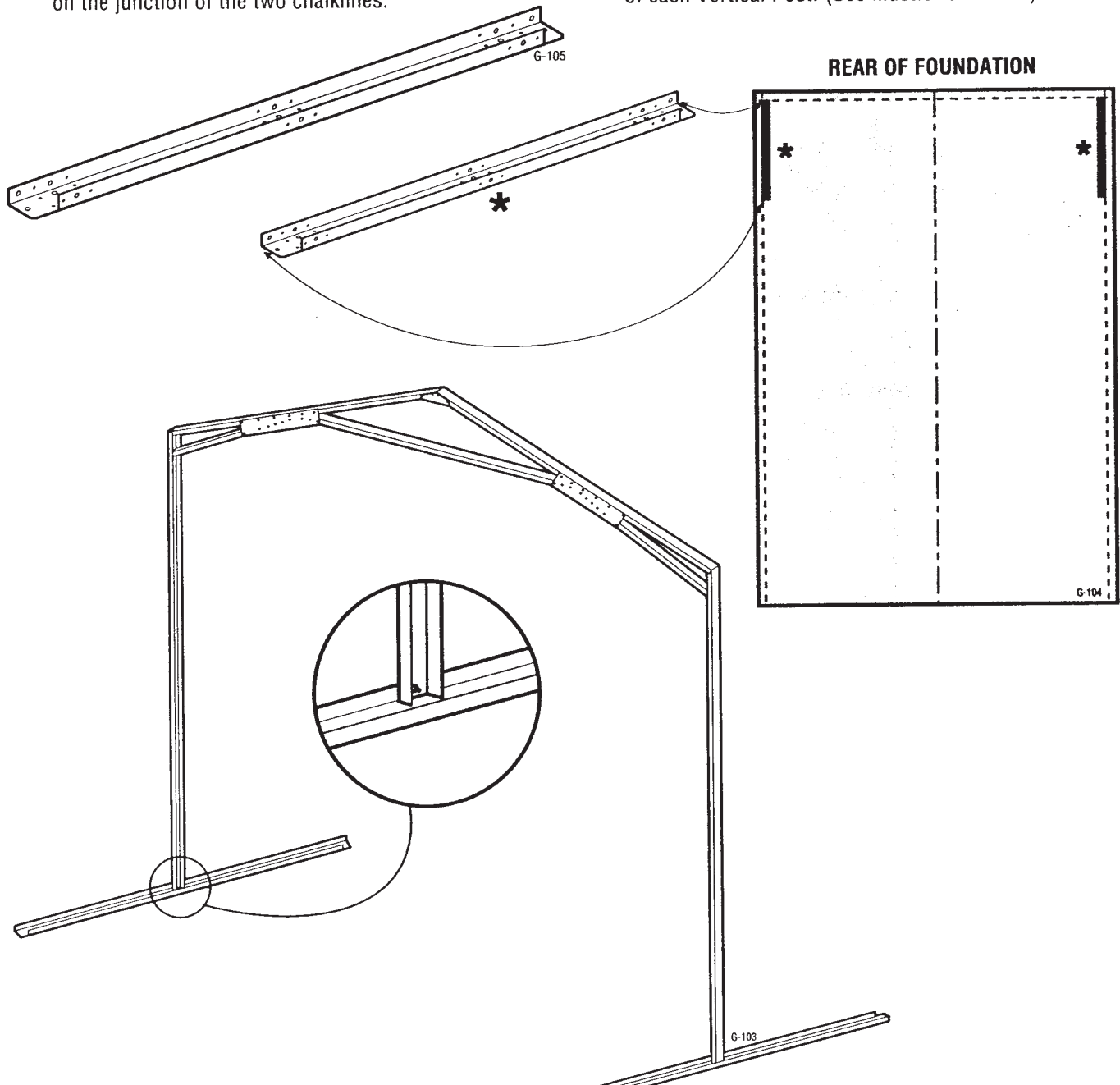

7.6 Position a second Truss assembly at the end of the Base Rails at the junction of the rear chalklines. **IT IS IMPORTANT THAT THIS TRUSS IS ATTACHED TO THE SECOND FROM THE END 6mm (1/4") FIXING HOLE OF THE BASE RAIL AT BOTH SIDES.** (See illustration on page 26.)

As each procedure is completed it is recommended that you and your assistant work on alternate sides of the building at the same time. Attaching components to both sides of the building in the following manner and order. Using a Spirit Level, ensure from time to time that the Truss sections are being attached in a vertical position.

7.7 Select (2) #1002 Mid Wall Brace components. Using a single bolt and nut through the end fixing holes provided in each Brace, attach both Mid Wall Braces to the second from the end Truss assembly. **INSTALLATION NOTE...** It is important that only the lower 6mm (1/4") side fixing holes in the Vertical Posts are used to attach the Mid Wall Braces. Repeat for opposite side.

7.8 Attach the Mid Wall Braces to the Rear Truss (see illustration on page 26) using a single bolt and nut through the Braces 6mm (1/4") fixing hole into the lower 6mm (1/4") fixing hole of the rear Truss. Repeat for opposite side.

TRUSS CONTAINING
SPECIAL 1029B BRACKET

1029B BRACKET
FACING REAR OF
BUILDING

N° 1001 BASE RAIL

N° 1002 MID
WALL BRACE

REAR OF FOUNDATION

293.8cm (115 1/2")

N° 1001 BASE RAIL

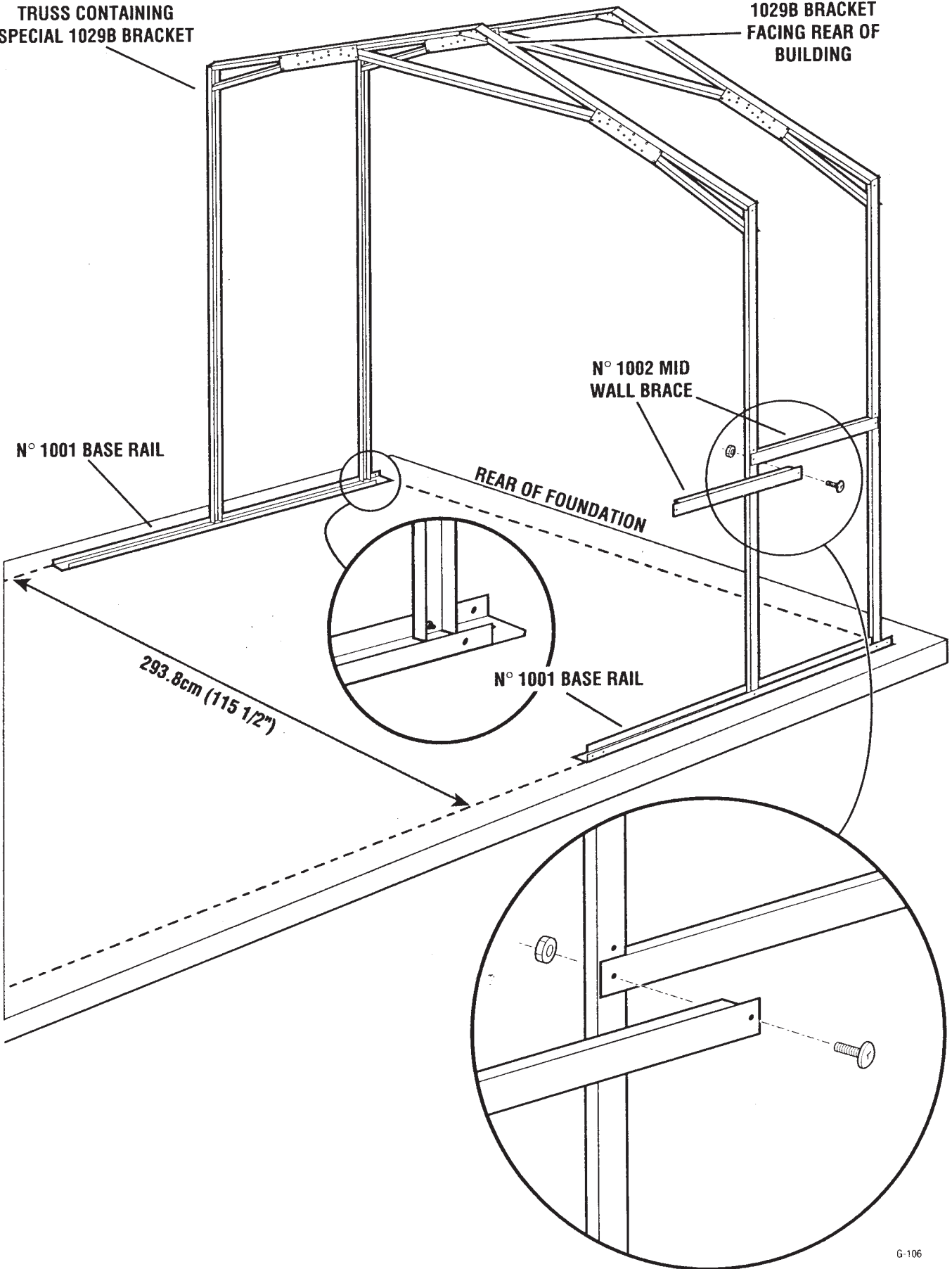

7.9 Place the Rear Wall Frame into position on the fixing holes located at the end of the Base Rails. Attach the Rear Wall Frame to the Base Rails using bolts and nuts. (It is essential that the #1029B Bracket attached to the Rear Wall Frame faces the #1029B Bracket located on the 2nd to last Truss and Post assembly). See illustration on Page 26.

7.10 Select a #1 Vertical Post Link. Using two (2) self tapping screws attach the Vertical Post Link to the upper set of smaller fixing holes that are located on the sides of the two Vertical Posts. (See illustration on Page 28 for details). Repeat for opposite side of building.

7.11 Select a #1003 Top Side Wall Rail. Using a bolt and nut through the upper centre fixing hole of the Top Wall Rail, attach Rail to the top fixing hole of the Truss assemblies #1010 Vertical Post. Repeat for opposite side of the building.

7.12 Using two (2) bolts and nuts, attach the rear fixing holes of the #1003 Top Side Wall Rail to the Rear Truss assembly and Rear Wall Frame (see illustration on Page 28 for details) where the two fixing holes align with the two Vertical Posts. Repeat for opposite side of the building.

7.13 Using a large spirit level, ensure the Truss assemblies are being placed in a vertical position each time. After ensuring that the Truss assemblies are vertical, place the #1042 Rear Wall Support Brace between the #1029B Bracket that is attached to the Rear Wall Frame and the #1029B Bracket of the second Truss assembly (see Figure "7a"). Using four (4) bolts and nuts, attach a #1042 Rear Wall Support Brace between the two (2) #1029B Brackets.

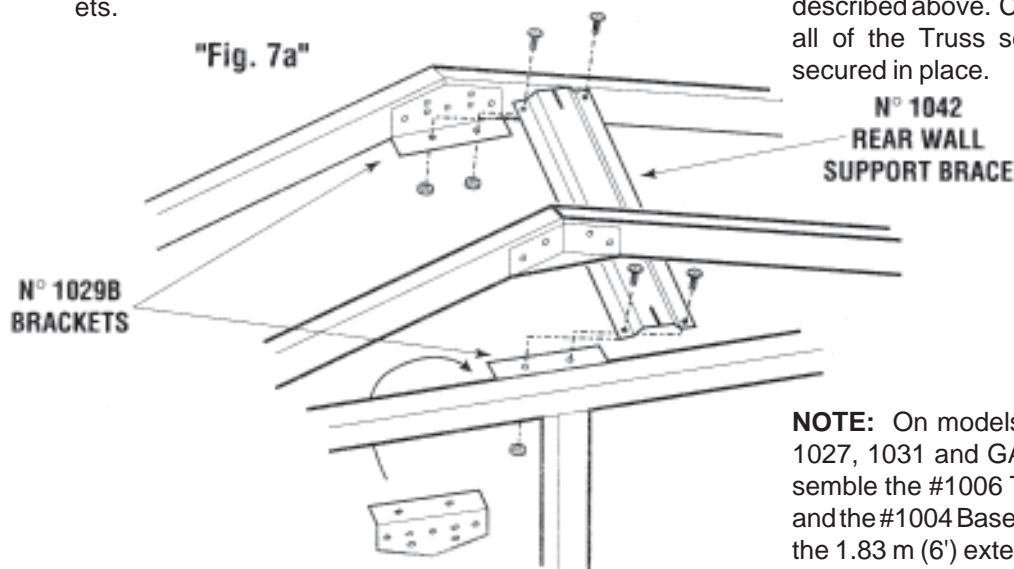

7.14 Select another #1001 Base Rail component. Using the two (2) 6mm (1/4") holes in the inside of the channel section as a guide, overlap the double set of 6mm (1/4") fixing holes. See Fig. 7.

INSTALLATION NOTE...DO NOT ATTACH BASE RAILS TOGETHER AT THIS TIME.

7.15 Select a completed Truss assembly and position on the centre of the joint of the two Base Rails. Using a bolt and nut, attach the double joint of the two Base Rail sections to the lower fixing hole of the Truss assemblies Vertical Post. (Repeat for opposite side of the building). See Fig. 7.

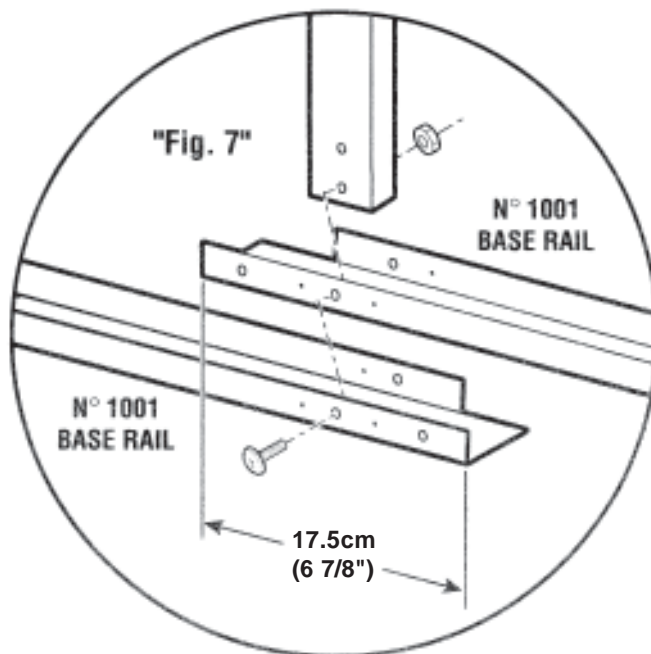

7.16 Continue to add Base Rails, Mid Wall Braces and Top Wall Rails using the same procedures as described above. Carry out these procedures until all of the Truss sections for your building are secured in place.

NOTE: On models GA1011, 1015, 1019, 1023, 1027, 1031 and GA1035 you are required to assemble the #1006 Top Side Wall Extension Rails and the #1004 Base Side Wall Extension Rails from the 1.83 m (6') extension module accordingly with the number of modules purchased.

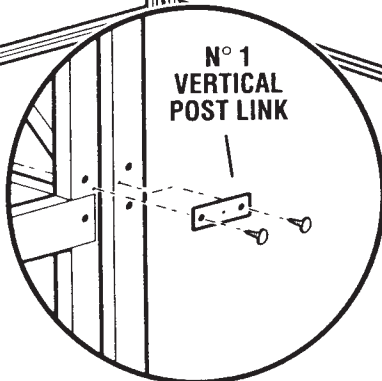
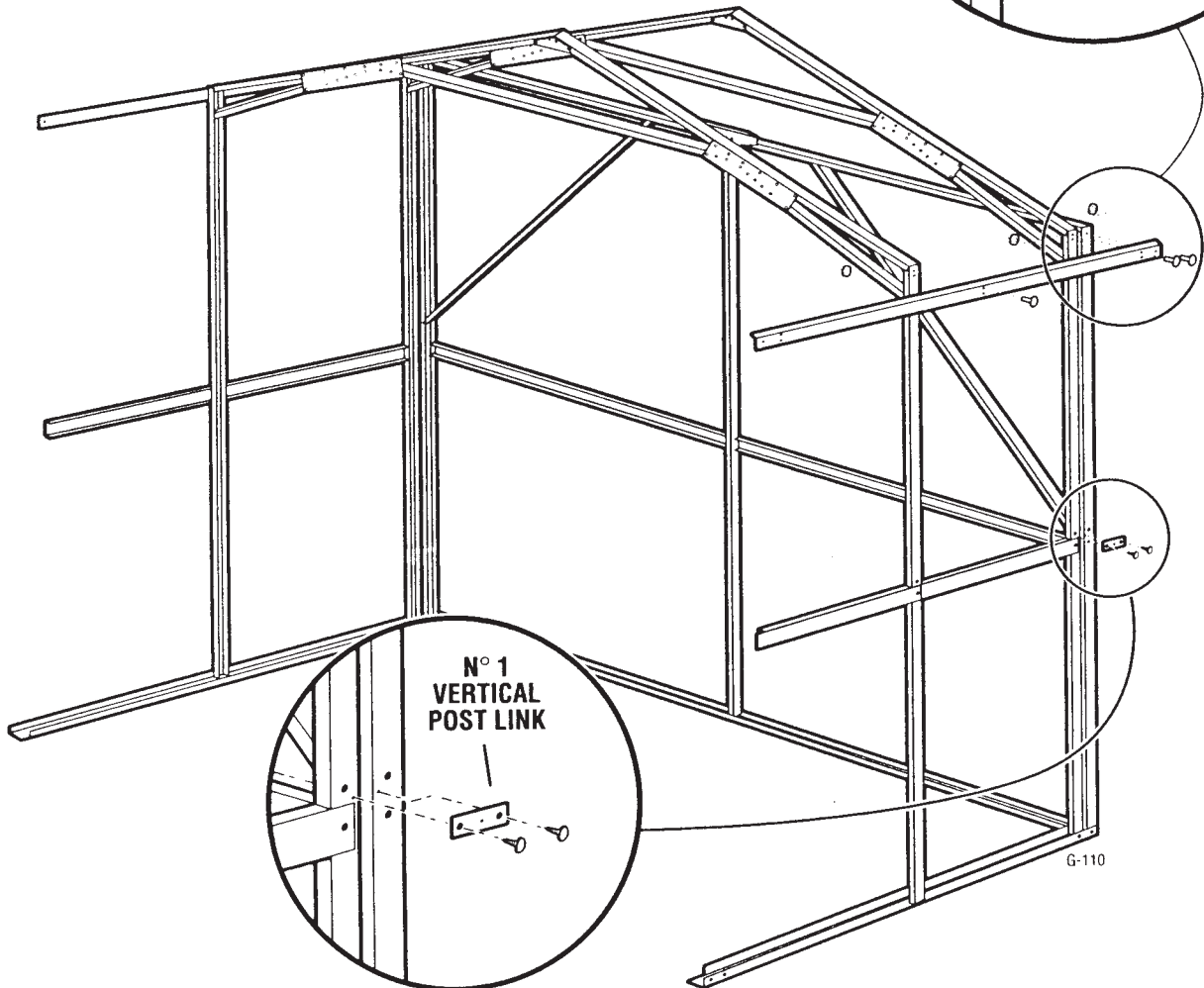
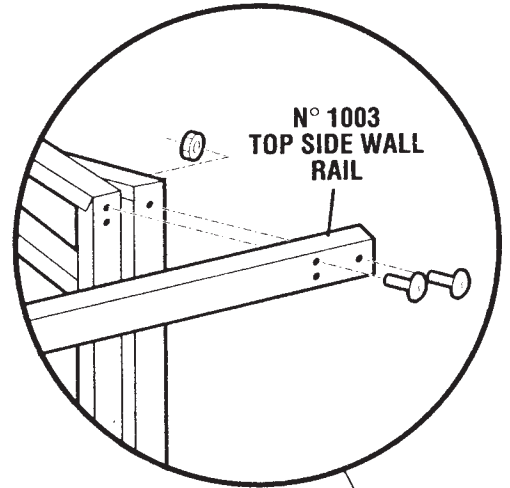
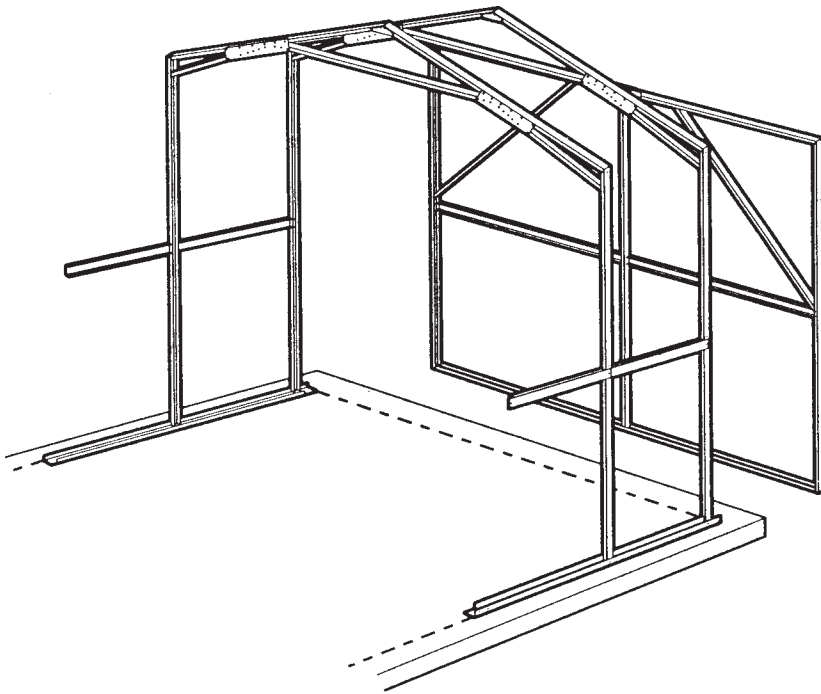

7.17 Select the #1027 Mid Wall Brackets. Using eight (8) Self Tapping Screws through the fixing holes provided, attach a Bracket to the junction of every Vertical Post and the Side Midwall Braces. See illustration below.

7.18 Position the previously assembled Front Entry Frame onto the ends of the Base Rails that protrude at the front of the building. (See illustration on page 30). Guide the Top and Bottom Wall Rails into position on the inside of the Front Corner Panels where the fixing holes align.

7.19 To attach the Front Entry Frame to the side wall rails it is required that a person on each corner use three (3) bolts, nuts, and plastic washers to attach the Front Entry Frame to the Base Rail and the Top Wall Rail.

INSTALLATION NOTE... The centre fixing bolt, nut and washer is required to pass through the vertical post of the Front Entry Frame only.

Ensure that all fasteners used in the structure are tight.

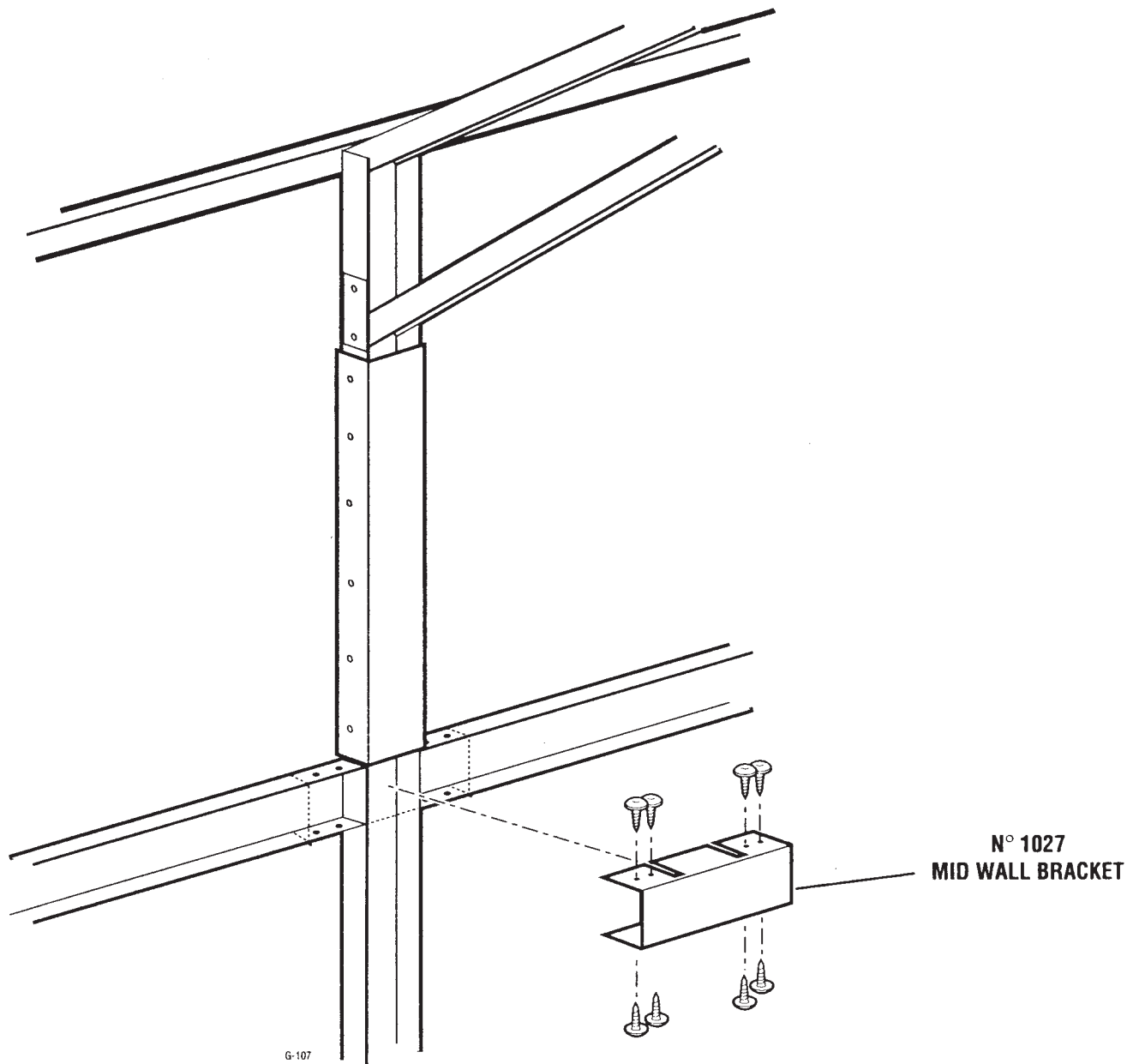

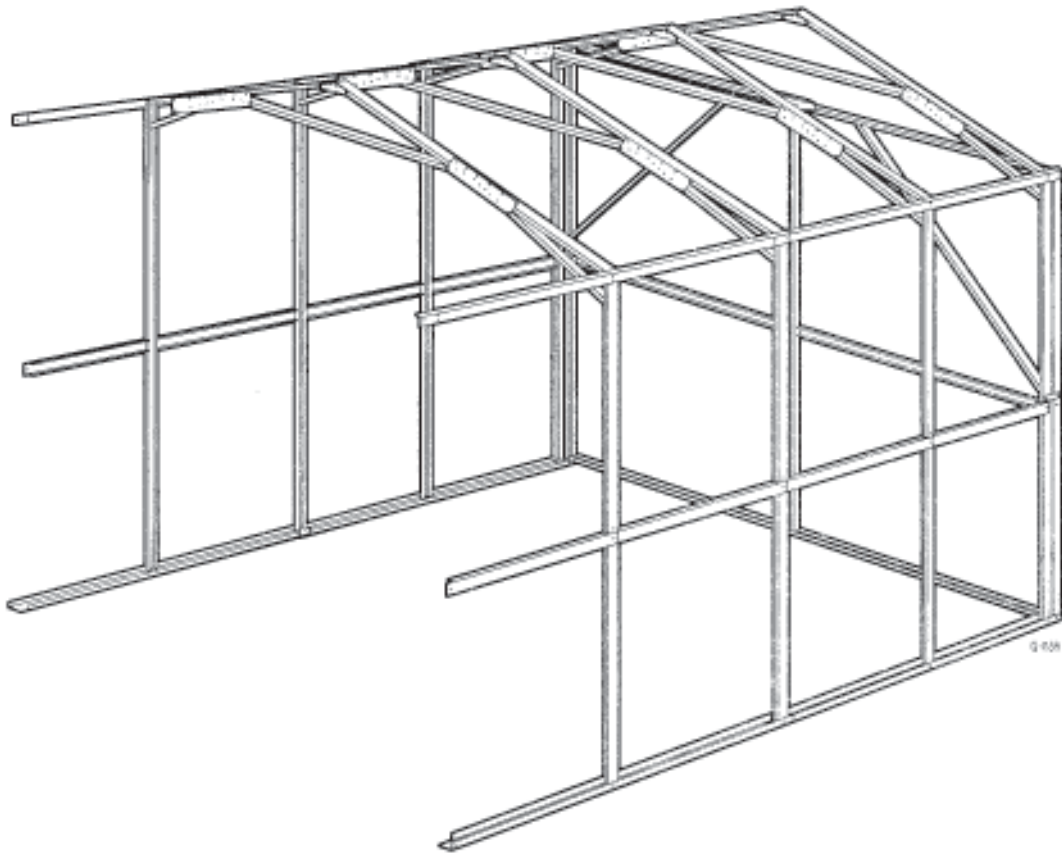

**BOLT AND N° P61
PLASTIC WASHER**

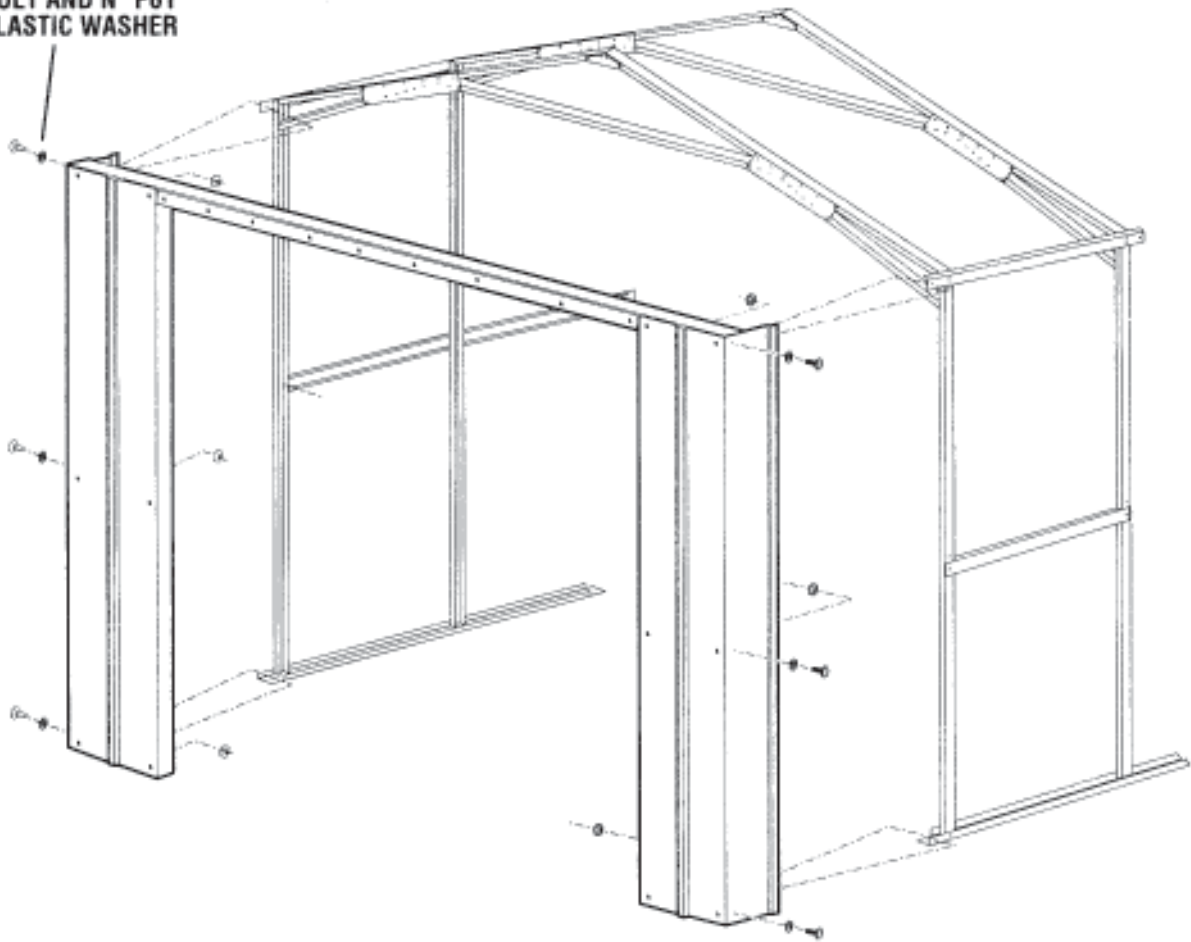

8

INSTALLATION OF RIDGE BEAMS

Working on a set of appropriate height and starting from the front of the structure, attach a #1032 Centre Ridge Beam Section by positioning the second set of 6mm (1/4") fixing holes over the centre of the Truss. (The Centre Ridge Beam is required to overhang the Truss by approximately 7.6cm (3") at the front of the building.) (See Fig. 8).

8.1 Using two (2) bolts and nuts, attach the Centre Ridge Beam to the apex of the Truss through the fixing holes provided.

INSTALLATION NOTE... A #1032 Centre Ridge Beam section is easily identified by its raised centre line as opposed to the flat upper surface of a #1038 Side Ridge Beam.

8.2 Attach Centre Ridge Beam to the second Truss in the same manner using the two 6mm (1/4") fixing that will align with those of the Truss Sections.

INSTALLATION NOTE... As you proceed across the entire roof, attaching the Centre Ridge Beams, you will come across sections where they are required to be overlapped above every alternate Truss assembly. To overlap any Ridge Beam section, align all four (4) 6mm (1/4") holes of each Ridge Beam section. At each join of the Ridge Beams the fixing bolts used are required to pass through both components and then through the Truss Sections. (See Fig. 8b on page 32.)

8.3 Continue to attach all Centre Ridge Beams across the entire structure using the same procedure described above. There will now be a 7.6cm (3") overhang of the Ridge Beam at both the front and rear of the building.

8.4 Select the #1038 Side Ridge Beams. Using the same instructions as the centre Ridge Beam proceed to attach both of the Side Ridge Beams using self tapping screws. **NOTE...** There will now be a 7.6cm (3") overhang on both front and rear Side Ridge Beams. (See Fig. 8a)

8.5 Continue to attach, overlap and secure both sets of Side Ridge Beams required by your model of building. (See Fig. 8c on page 32.)

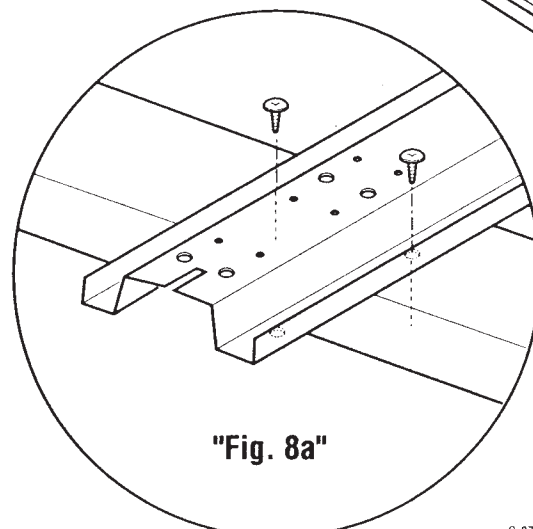
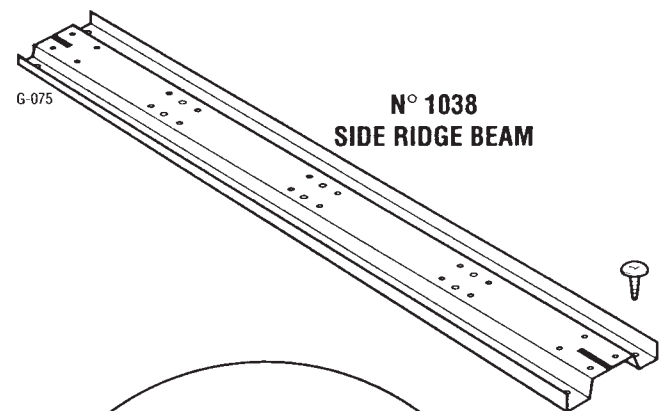
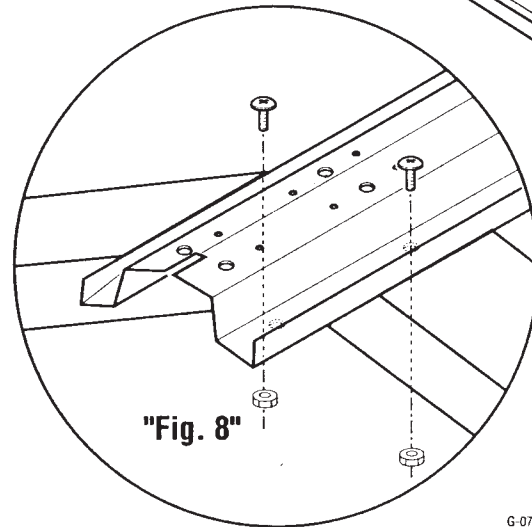
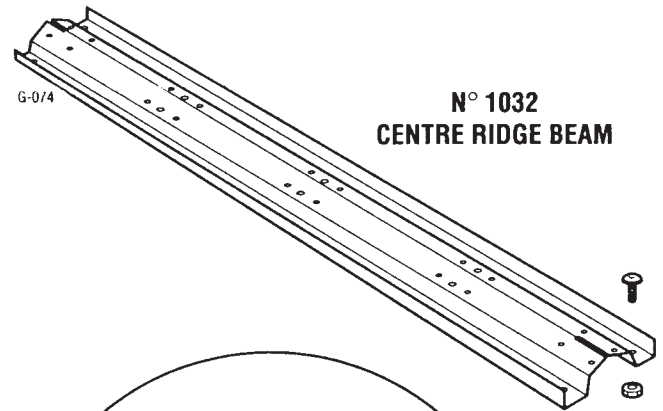

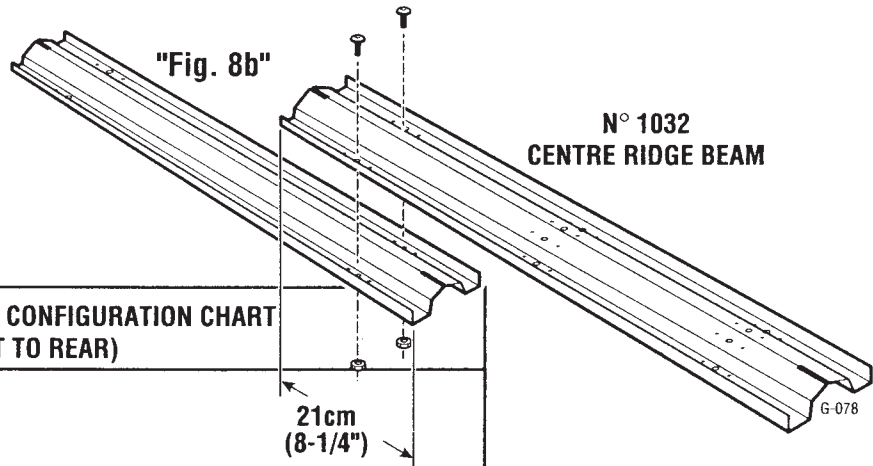

**CENTRE RIDGE BEAM CONFIGURATION CHART
(FRONT TO REAR)**

GA105	1032
GA109	1032 + 1032
GA1011	1032 + 1032 + 1037
GA1013	1032 + 1032 + 1032
GA1015	1032 + 1032 + 1032 + 1037
GA1017	1032 + 1032 + 1032 + 1032
GA1019	1032 + 1032 + 1032 + 1032 + 1037
GA1021	1032 + 1032 + 1032 + 1032 + 1032
GA1023	1032 + 1032 + 1032 + 1032 + 1032 + 1037
GA1025	1032 + 1032 + 1032 + 1032 + 1032 + 1032
GA1027	1032 + 1032 + 1032 + 1032 + 1032 + 1032 + 1037
GA1029	1032 + 1032 + 1032 + 1032 + 1032 + 1032 + 1032
GA1031	1032 + 1032 + 1032 + 1032 + 1032 + 1032 + 1032 + 1037
GA1033	1032 + 1032 + 1032 + 1032 + 1032 + 1032 + 1032 + 1032
GA1035	1032 + 1032 + 1032 + 1032 + 1032 + 1032 + 1032 + 1032 + 1037

NOTE... Models GA1011, GA1015, GA1019, GA1023, GA1027, GA1031 and GA1035 require extension ridge beam sections N° 1037 being added to the ridge beam assembly at the rear of the building.

The number of parts will vary accordingly to the number of extension modules purchased. Use this table as a guide.

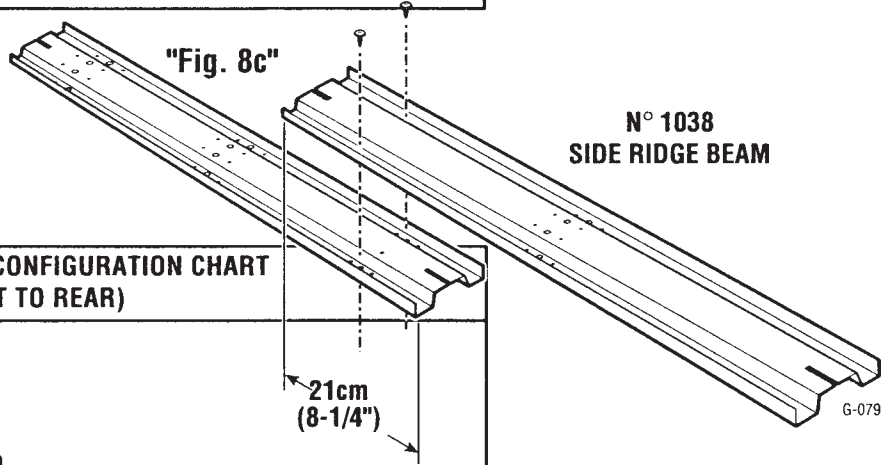

**SIDE RIDGE BEAM CONFIGURATION CHART
(FRONT TO REAR)**

GA105	1038
GA109	1038 + 1038
GA1011	1038 + 1038 + 1039
GA1013	1038 + 1038 + 1038
GA1015	1038 + 1038 + 1038 + 1039
GA1017	1038 + 1038 + 1038 + 1038
GA1019	1038 + 1038 + 1038 + 1038 + 1039
GA1021	1038 + 1038 + 1038 + 1038 + 1038
GA1023	1038 + 1038 + 1038 + 1038 + 1038 + 1039
GA1025	1038 + 1038 + 1038 + 1038 + 1038 + 1038
GA1027	1038 + 1038 + 1038 + 1038 + 1038 + 1038 + 1039
GA1029	1038 + 1038 + 1038 + 1038 + 1038 + 1038 + 1038
GA1031	1038 + 1038 + 1038 + 1038 + 1038 + 1038 + 1038 + 1039
GA1033	1038 + 1038 + 1038 + 1038 + 1038 + 1038 + 1038 + 1038
GA1035	1038 + 1038 + 1038 + 1038 + 1038 + 1038 + 1038 + 1038 + 1039

NOTE... Models GA1011, GA1015, GA1019, GA1023, GA1027, GA1031 and GA1035 require extension ridge beam sections N° 1039 being added to the ridge beam assembly at the rear of the building.

The number of parts will vary accordingly to the number of extension modules purchased. Use this table as a guide.

9

ATTACHING WALL PANELS

IMPORTANT INSTALLATION NOTE... Before starting to attach Wall Panels you must ensure that your building is square.

INSTALLATION NOTE... As each Wall Panel is positioned, you must first secure the Panels together using a bolt, nut and plastic washer. This fixing bolt (see Fig. 9) is required to pass through the side fixing holes on the raised flange of each panel prior to fitting the panel with any self tapping screws. This task is better accomplished if your helper is positioned on the inside of the structure fitting the nuts to the bolts where required, while you position and secure each Wall Panel from outside of the building. See Fig. 9.

9.1 Starting from the front of the building and working on alternate sides of the building, attach Wall Panels to the sides of the building, ending up at the rear.

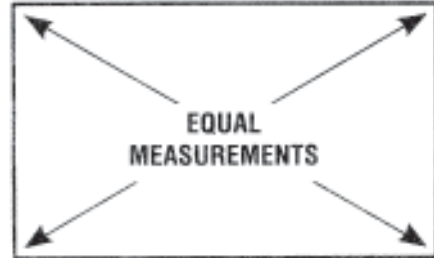

"Fig. 9"

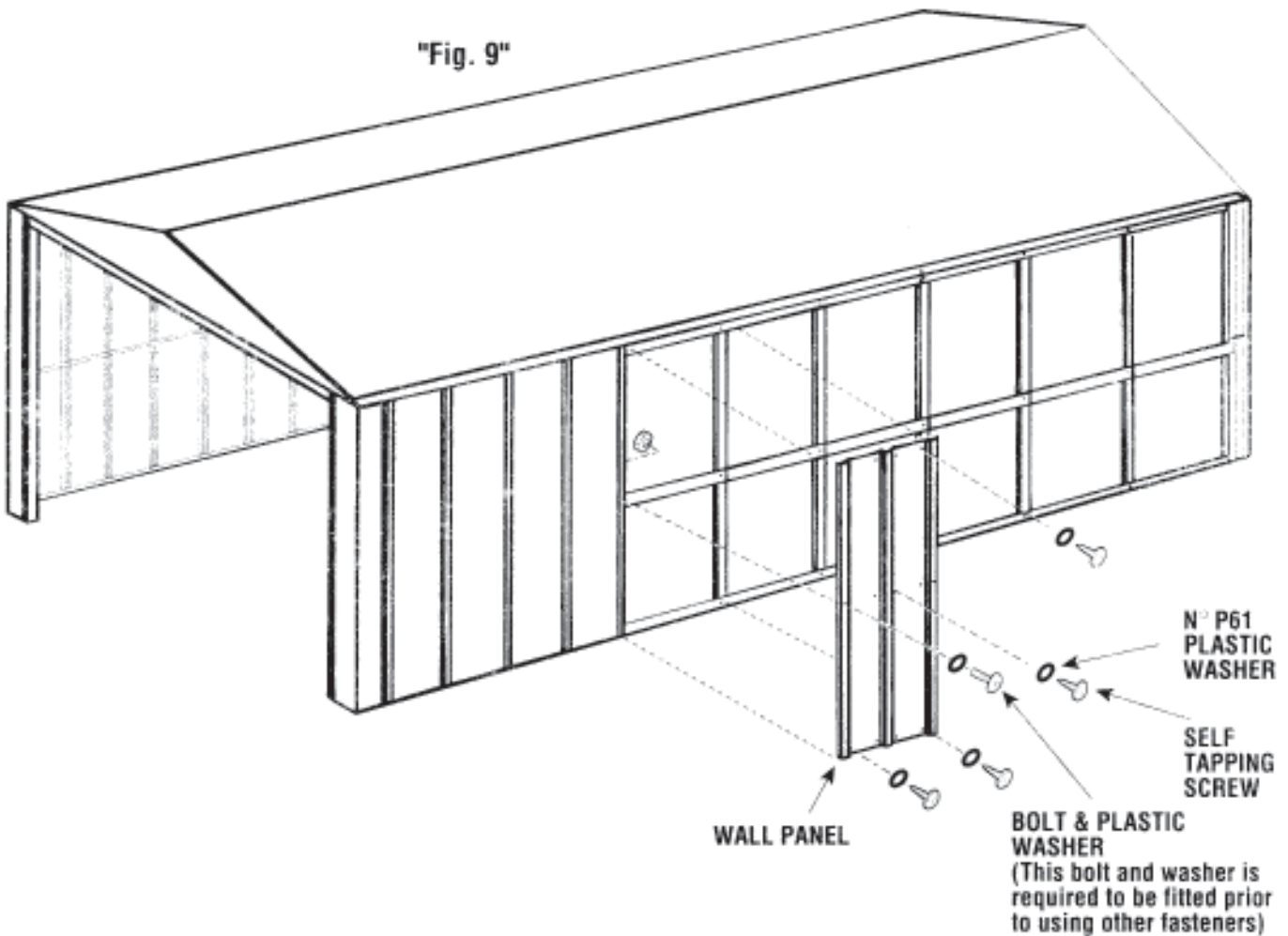

10

GABLE ASSEMBLY

For a Gable you will require: (1) #1042HH a pre-painted component, (1) #1043HH a pre-painted component and (8) #33 Brackets. Refer to Fig. 10.

INSTALLATION NOTE... The Gables may have sharp edges. Use protective work gloves while handling these components.

- 10.1 Working on a level surface, position the Gable sections side by side so that the flange sections of the Gables face upward.
- 10.2 Select four (4) #33 Gable Brackets. Position two (2) Brackets on the left hand side of the Gables flange and two (2) Brackets on the right hand side of the flange. Using bolts and nuts attach Brackets and Gables together through the seven (7) fixing holes in the Brackets and the Gable sections. See Fig. 10a.
- 10.3 Select two (2) #33 Gable Brackets. Position the two (2) Brackets side by side, attach them together using two (2) bolts and nuts through the top and bottom fixing holes only. See Fig. 10a.
- 10.4 Position this pair of Gable Brackets to the inside surface of the Gables where the four (4) fixing holes in the Gables surface align with those of the Gable Bracket. Using four (4) Bolts, Nuts and Plastic Washers, attach Gable Brackets to the inside surface of the Gable. (Repeat procedure to attach opposite side of Gable). See Fig. 10a.
- 10.5 Assemble a second Gable assembly using the same procedure as described above.

GABLE INSTALLATION

Rear Gable installation

- 10.6 Working from a balanced Step Ladder on the outside of the building, position a Gable with it's flanged edges facing towards the interior of the building, the front surface is required to overhang the Wall Panels raised flanges. See Fig. 10.
- 10.7 Position the Gable so that the 6mm (1/4") fixing holes in the Gable align with the smaller outer fixing holes on the Top Rear Wall Frame. Using self tapping screws, attach Gables.
- 10.8 Attach the front Gable using the same instructions as used for the rear Gable.

"Fig. 10a"

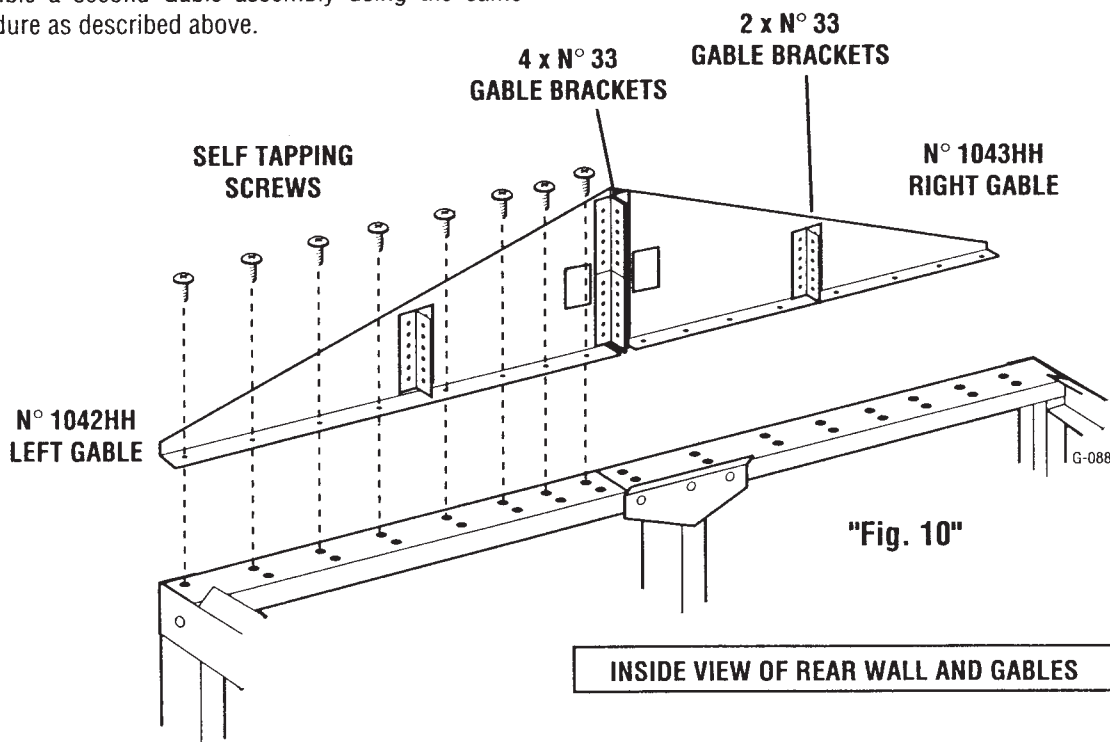
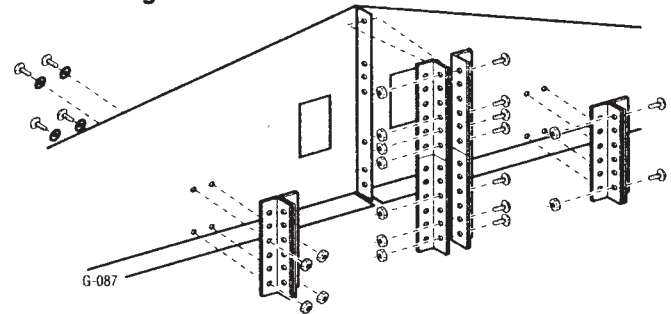

11 ATTACHING ROOF END PANELS

INSTALLATION NOTE...Before attempting to attach any of the Roof Panels it is necessary to ensure once again that the building is square.

IMPORTANT NOTE...As you attach the Roof Panels, each fastener used in the following procedure is required to be fitted with a #P61 Plastic Washer.

- 11.1 Select a left and right hand Roof End Panel #1018VS (left hand side) #1044VS (right hand side)
- 11.2 Working on a Step Ladder, position yourself between the first and second Truss sections. Align the 6mm (1/4") fixing holes of the Right Gable with the 6mm (1/4") fixing holes of the left-hand Roof End Panel. Using bolts, nuts and Plastic Washers through the 6mm (1/4") fixing holes, attach both components together. See Fig. 11.
- 11.3 Using self tapping screws and Plastic Washers, secure the End Roof Panel to the Centre Ridge Beam, Side Ridge Beam and Side Wall Brace.
- 11.4 Repeat the same procedure and methods to install the right-hand side End Roof Panel, and also the two End Roof Panels at the opposite end of the building.

INSTALLATION OF ROOF PANELS AND ASSOCIATED FITTINGS

INSTALLATION NOTE...As you proceed to assemble the roof, several components are required to be attached or fitted at the same time. This task is best performed by two persons working together as a team, one person working on the inside of the building, while the other person works on the outside of the building offering the roof components, when required.

While fitting Roof Panels it is necessary to apply the adhesive Aluminum Tape and also fit the #2 Ridge Cover Mounting Brackets to the join formed by the two Roof Panels at the apex of the roof. The adhesive Aluminum Weather Seal Tape is required to be applied across the entire roof of the building while you proceed to attach the Roof Panels on alternate sides of the building. (See illustration on Page 36 for details of the required positioning of roofing components for your model of building.)

- 11.5 Starting from the Rear of the building, position a Translucent Roof panel over the raised flanged section of the End Roof Panel. Attach the Translucent Roof Panel to the End Roof Panel using a single bolt, nut and Plastic Washer through the fixing hole in the raised flange section of the Panel above the Side Ridge Beam. See Fig. 11a.

NOTE...The 1/4" fixing holes on the upper corner of the raised flange are not used to attach the roof Panels on this building. This hole should be left blank. See Fig. 11a. Cut 8 short 5cm (2") strips off the roll of weather seal tape. Cover the 1/4" fixing holes with strip of weather seal tape.

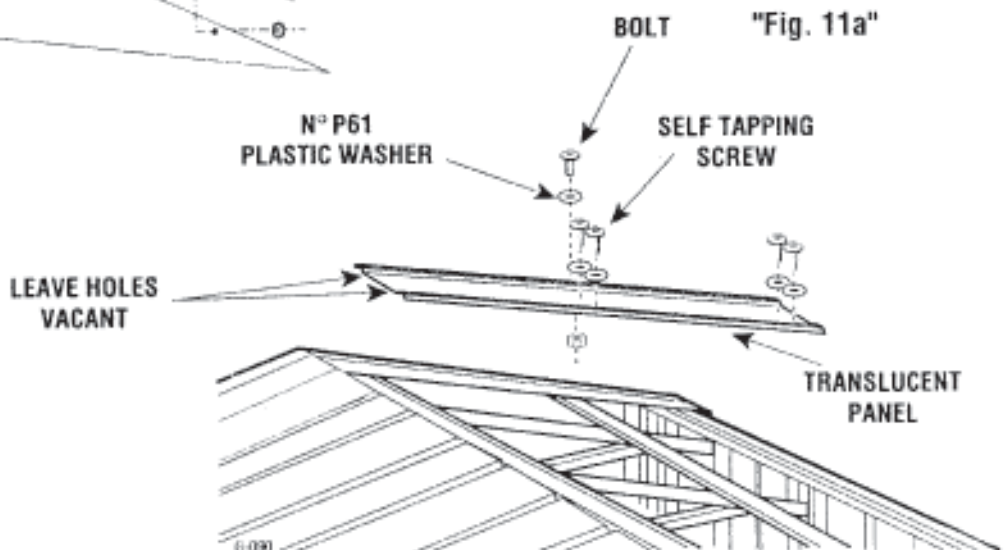
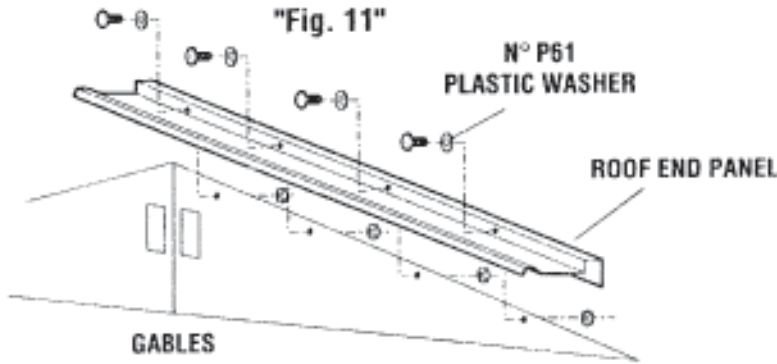

ROOF PANEL POSITIONING CHART (FRONT TO REAR)

GA1035	
GA1033	
GA1031	
GA1029	
GA1027	
GA1025	
GA1023	
GA1021	
GA1019	
GA1017	
GA1015	
GA1013	
GA1011	
GA109	
GA105	

EP = END PANEL
TP = TRANSLUCENT PANEL
MB = MOUNTING BRACKET

INSTALLATION NOTE... While fitting the opposite side roof panels it is important to note that the roof weather seal tape and #2 Ridge Cover Mounting Brackets must also be fitted as you proceed along the building.

The number of parts will vary accordingly to the number of extension modules purchased. Use this table as a guide.

- 11.6 Select a roll of Weather Seal Tape. Start applying tape to the End Roof Panels above the Gable sections. Apply Weather Seal Tape evenly across the joint formed by the two Roof End Panels and the two Translucent Panels. (See Fig. 11b.) **DO NOT TEAR OFF THE WEATHER SEAL TAPE.**
 - 11.7 Using Self Tapping Screws and Plastic Washers, continue to attach the Roof Panels and Roof Rafters. Roof Panels are secured at the Centre Ridge Beam, Side Ridge Beam and Top Wall Rails. Roof Rafters are secured at the Centre Ridge Beam and Top Wall Rails only. (See Fig. 11b) Repeat for opposite side of the building.
- NOTE:** Using the Roof Panel Positioning Chart, attach the Ridge Cover Mounting Brackets where they are required. These Brackets are attached by self tapping screws through the Roof Panel fixing holes into the Centre Ridge beam.
- 11.8 Place Roof Panel into position on the side of the roof, and using a single bolt, nut and #P61 Plastic Washer, attach Roof Panel to the Translucent Roof Panel using the fixing hole of the raised flange section just above the Side Ridge Beam. See Fig. 11b.

- 11.9 Using the Roof Panel Positioning Chart note the location of the #HH10RW Roof Rafters. Be sure to fit these Roof Rafters in their proper position in the centre of each Full Roof Panel. See Fig. 11b.
- 11.10 Using self tapping screws fitted with Plastic Washers, attach the Roof Panel and Roof Rafter to the Centre Ridge Beams and Top Wall Rails in the same manner as previously used.

IMPORTANT INSTALLATION NOTE...It is necessary that after installing and completing 3 sections of Roof Panels, a Ridge Cover is fitted across the Ridge Cover Mounting Brackets that you have attached up to this point. (See chart below for the part number of the Ridge Covers required to be attached to this section of the building.) Where required, overlap the notched sections of each Ridge Cover component.

- 11.11 Continue to attach and seal all Roof Panels as you proceed across the entire roof using the same procedures and methods as described in previous steps.

RIDGE COVER CHART (FRONT TO REAR)	
GA105	520H
GA109	520H + 920H
GA1011	520H + GA20
GA1013	520H + 920H + 920H
GA1015	520H + GA20 + 920H
GA1017	520H + 920H + 920H + 920H
GA1019	520H + GA20 + 920H + 920H
GA1021	520H + 920H + 920H + 920H + 920H
GA1023	520H + GA20 + 920H + 920H + 920H
GA1025	520H + 920H + 920H + 920H + 920H + 920H
GA1027	520H + GA20 + 920H + 920H + 920H + 920H
GA1029	520H + 920H + 920H + 920H + 920H + 920H + 920H
GA1031	520H + GA20 + 920H + 920H + 920H + 920H + 920H
GA1033	520H + 920H + 920H + 920H + 920H + 920H + 920H + 920H
GA1035	520H + GA20 + 920H + 920H + 920H + 920H + 920H + 920H

The number of parts will vary accordingly to the number of extension modules purchased. Use this table as a guide.

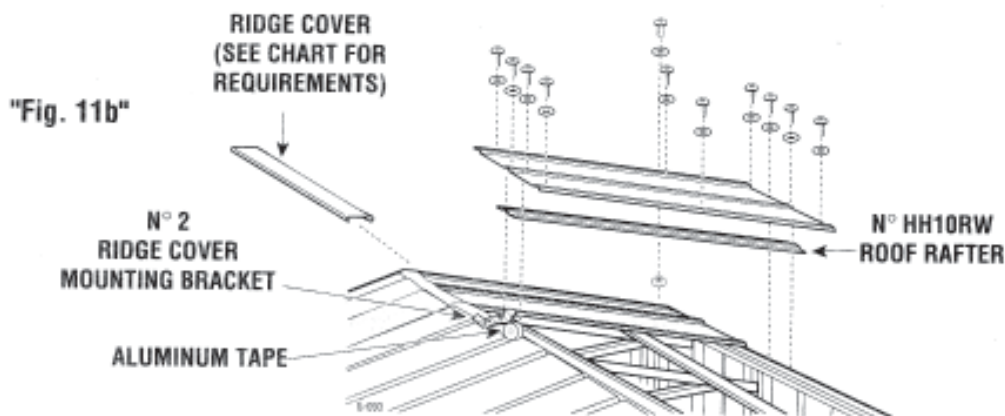

12 ANCHORING THE STRUCTURE

NOTE...At this point you should anchor the building to it's foundation. The anchoring locations that you should use are the inner of the two 6mm (1/4") holes found in the Base Rail at the bottom of each Vertical Post (see Fig. 12b). It is recommended that heavy duty 50mm x 6mm (2" x 1/4") Anchors and Washers are used for these fixings. Anchoring is to be done every 60 cm (24") or more frequently if necessary.

12.1 Ensure your building is completely square on it's foundation. This can be confirmed by ensuring that the diagonal dimensions from corner to corner are exactly the same. See Fig. 12a.

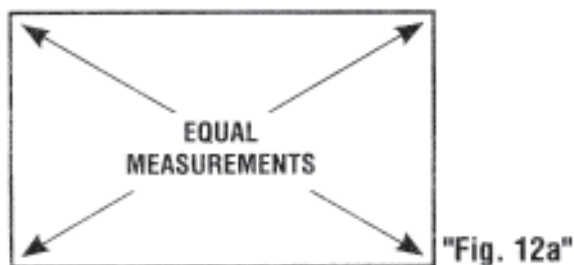

12.2 Following the directions given for your chosen anchors, drill and install your anchors as directed by their manufacturer.

FOR EUROPE ONLY: For concrete base use the following: hole depth = 70mm; plug length = 50 mm; screw length = 60 mm; screw diameter = 8 mm (as per DIN 571).

For wood base use screws with length = 80 mm and 8mm in diameter as per DIN 571.

Note 1: The installer must use the correct size drill to make the appropriate holes in the base.

Note 2: Anchoring should be done every 60 cm on each section of the base.

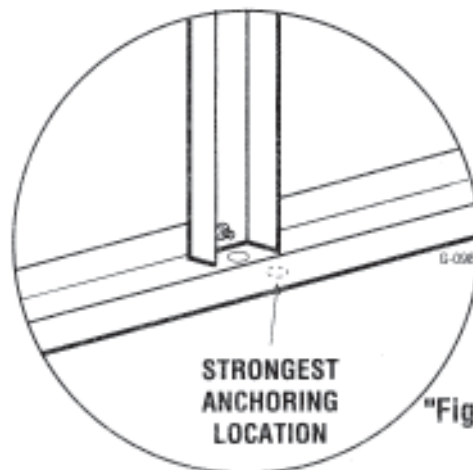

Quantity of Anchors Required				
Model	Front	Rear	Sides	Total
GA105	4	3	6	13
GA109	4	3	10	17
GA1011	4	3	12	19
GA1013	4	3	14	21
GA1015	4	3	16	23
GA1017	4	3	18	25
GA1019	4	3	20	27
GA1021	4	3	22	29
GA1023	4	3	24	31
GA1025	4	3	26	33
GA1027	4	3	28	35
GA1029	4	3	30	37
GA1031	4	3	32	39
GA1033	4	3	34	41
GA1035	4	3	36	43

The number of anchors will vary accordingly to the number of extension modules purchased. Use this table as a guide.

13 DOOR FRAME ANCHORING BRACKETS

13.1 Select the two (2) #1033 Door Frame Anchoring Brackets. Using a bolt and nut, attach a Bracket to the bottom of each of the front entrance Vertical Posts. (See Fig. 13.)

13.2 Using your chosen anchors, attach Door Frame Anchoring Brackets to your foundation.

The installer must use the correct size drill to make the appropriate holes in the Door Frame Anchoring Brackets.

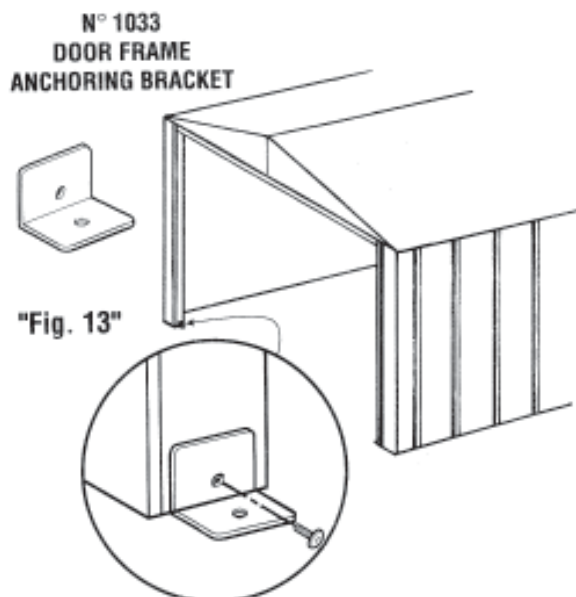

14 ATTACHING ROOF EDGE TRIM

From the chart select the Roof Edge Trim components required by your model of building.

- 14.1 Starting from the front of the building, using bolts and nuts attach one section at a time to the outermost 6mm (1/4") fixing holes of the Roof Panels. **DO NOT TIGHTEN BOLTS AT THIS TIME.**
- 14.2 Where two Edge Trims join, it is necessary to overlap the two 6mm (1/4") holes of each Trim and using the second 6mm (1/4") fixing hole of each Edge Trim to make the join. **TIGHTEN THIS BOLT.** See Fig. 14.
- 14.3 Continue to attach and overlap the Roof Edge Trim sections along the entire length of the building, leaving the bolts and nuts attached to the roof panels loose until instructed to tighten them.
- 14.4 Attach Roof Edge Trims on the opposite side of the building using the same instructions.

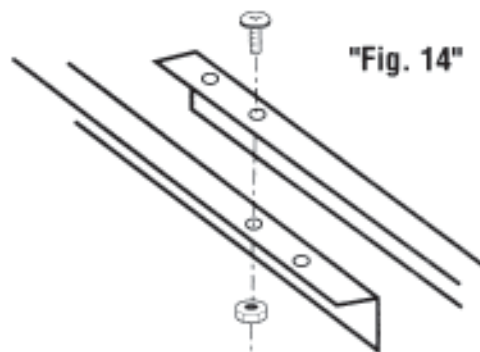

"Fig. 14"

LEFT AND RIGHT ROOF EDGE TRIM ASSEMBLY (LISTED FRONT TO REAR)

GA105	541H
GA109	541H + 541H
GA1011	541H + GA41
GA1013	541H + 541H + 541H
GA1015	541H + GA41 + 541H
GA1017	541H + 541H + 541H + 541H
GA1019	541H + GA41 + 541H + 541H
GA1021	541H + 541H + 541H + 541H + 541H
GA1023	541H + GA41 + 541H + 541H + 541H
GA1025	541H + 541H + 541H + 541H + 541H + 541H
GA1027	541H + GA41 + 541H + 541H + 541H + 541H
GA1029	541H + 541H + 541H + 541H + 541H + 541H + 541H
GA1031	541H + GA41 + 541H + 541H + 541H + 541H + 541H
GA1033	541H + 541H + 541H + 541H + 541H + 541H + 541H + 541H
GA1035	541H + GA41 + 541H + 541H + 541H + 541H + 541H + 541H

The number of parts will vary accordingly to the number of extension modules purchased. Use this table as a guide.

15 ROOF CORNER CAPS

- 15.1 Select the four (4) #60H Roof Corner Caps. Remove the previously left loose fixing bolt from the front corner of the Front Roof Panel and the Roof Edge Trim. Position a Roof Corner Cap over the end of the Roof Edge Trim. Using a bolt and nut through the empty 6mm (1/4") fixing hole, attach the Corner Cap to the Roof Edge Trim and Roof Panel. See Fig. 15.
- 15.2 Repeat procedure on the remaining three corners of the building.
- 15.3 Tighten all Roof Edge Trim fixing bolts.

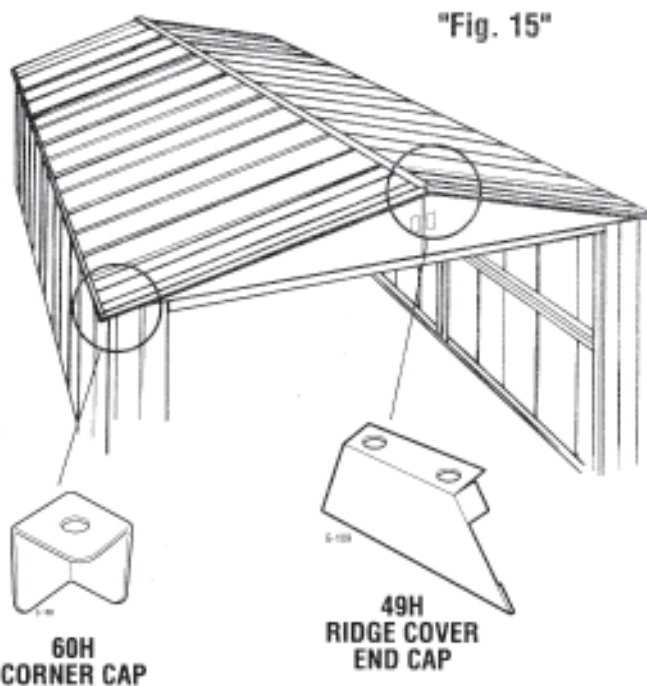

"Fig. 15"

16 RIDGE COVER END CAPS

- 16.1 Fit a #49H Ridge Cover End Cap into position at the end of the Ridge Cover. Using two (2) self tapping screws, and working on the underside of the Roof End Panel next to the gables surface, insert the two self tapping screws into the two fixing holes of the Ridge Cover End Cap. See Fig. 15.
- 16.2 Repeat procedure to attach the opposite end Ridge Cover End Cap.

17 LOUVER INSTALLATION

- 17.1 Select a #13-100 Louver. Have an assistant hold the Louver to the outside surface of the Gable while attaching it from the inside of the building using two (2) self tapping screws and plastic washers. See Fig. 17.
- 17.2 Repeat procedure to attach the opposite end Louver.

18 EMBLEM INSTALLATION (OPTIONAL)

- 18.1 Select the two (2) #13-007 Emblems and two (2) #80 Double Sided Adhesive Pads. Remove the protective backing from the Adhesive Pads and attach two pads to the rear surface of the Emblem. Position the Emblem at your desired location on the Front Gable. Press the Emblem against the Gable so that the Adhesive Pads make full contact with the Gables surface. Repeat procedure to attach the second Emblem.

19 INSTALLATION OF WEATHER SEAL FOAM TAPE

- 19.1 Select the #BT1A Weather Seal Foam Tape. Position a length of Foam Tape down the side of the Door Posts next to the hinges. See Fig. 18.

20 HANGING THE TWO DOUBLE DOORS

- 20.1 With assistance, position one of the previously assembled doors in the front entrance of the building. Align the three side 6mm (1/4") fixing holes with the Hinge. Using three (3) countersunk bolts, nuts and the large washers attach the Door to the Hinge. **DO NOT TIGHTEN BOLTS FULLY AT THIS TIME.**
- 20.2 Position the lower set of fixing holes with the fixing holes of the Hinge. Using three (3) countersunk bolts, nuts and washers attach the Door to the lower Hinge. Ensure the Door is level and closes properly. If necessary, slight adjustment can be made by loosening the countersunk bolts and making the adjustment required. Tighten all hinge countersunk bolts.
- 20.3 Repeat procedure to hang the opposite side door assembly.
- 20.4 Upon completion of the building, in its final position on the foundation, you will be required to drill two (2) 12.7mm (1/2") holes in the foundation at the centre of the entrance area. These holes will allow the Cane Bars to hold the double doors in a closed position. It is also necessary that when both doors are fully opened, 12.7mm (1/2") holes are drilled in the driveway where you wish the Cane Bars to hold the doors in the open position.

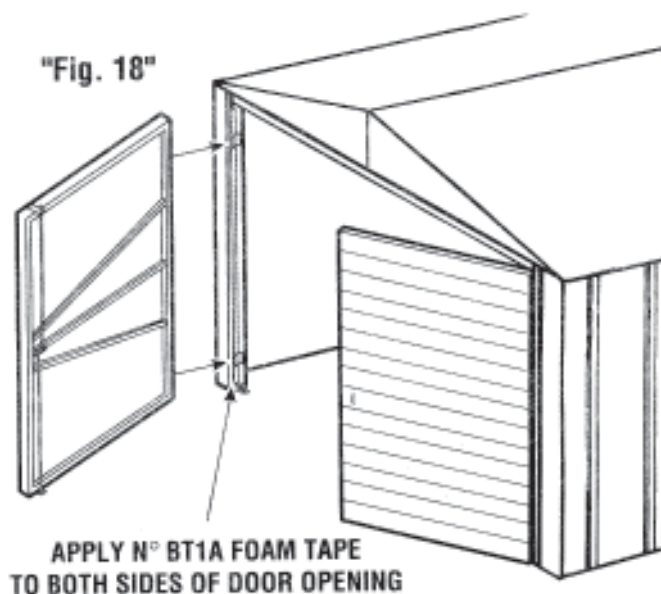
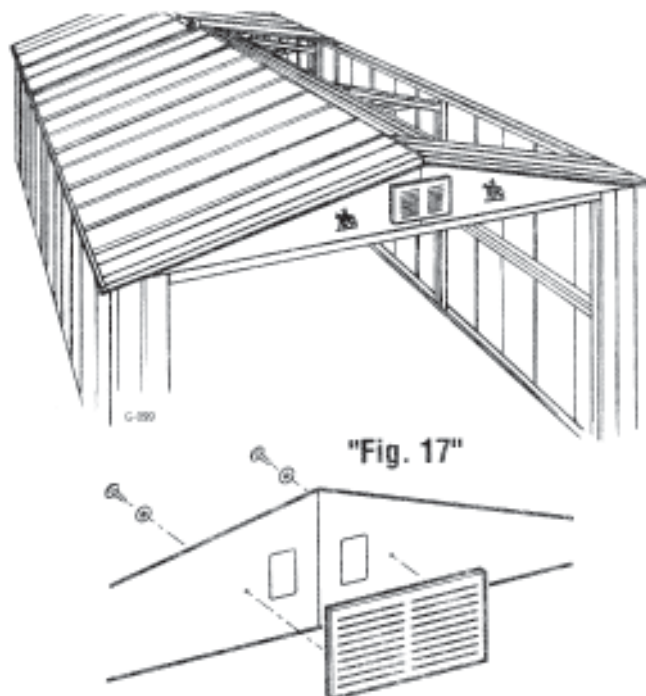

FOR YOUR PERSONAL SAFETY PLEASE READ THE FOLLOWING PRECAUTIONS

W41

1. For your safety and to prevent damage to the roof of your building do not stand on the roof.
2. During winter do not allow more than 25cm (10") of snow to accumulate on the roof. Under such conditions occupancy may become hazardous and must be avoided.

FOR NORTH AMERICA: This building has a load carrying capacity of 27.5 psf live load on the horizontal projection of the roof in accordance with CSA std. S136M89.

FOR EUROPE ONLY: This building has sufficient loadbearing capacity for a snow load of $S_o = 0.75 \text{ kNM}^2$ and for wind loads as per DIN 1055, sheet 4, or for a combination of loads, as per Expertise no. 9700407 dated April 18, 1997 from VSL Consulting Engineers for Light Construction, Karlsruhe, Germany and documented in VA reports nos. 963002 and 963041. This document is available upon request from purchaser.

3. Do not run any type of internal combustion engine in a confined space such as this building. The odourless gasses produced by internal combustion engines are extremely hazardous.
4. Do not use any form of sling or lifting device that attaches to any part of the building. The truss and roof sections are designed only to support the buildings structure.

BUILDING CARE

- **Carefree maintenance** - Your building has been designed to give you years of carefree service. All parts have been precision engineered for perfect fit. It is manufactured from heavily galvanized steel with exterior parts pre-enameled on both sides at the steel mill.
- **IMPORTANT** - This building is designed to withstand normal snow and wind loads when installed according to instructions. Spacemaker Ltd. cannot be held responsible for any consequences due to buildings that are not installed per instructions or for damage due to weather conditions or acts of God.

REPLACEMENT PARTS OR ANY QUESTIONS REGARDING YOUR BUILDING SHOULD BE REFERRED DIRECTLY TO CUSTOMER SERVICE. DO NOT CONTACT YOUR DEALER, THEY ARE NOT EQUIPPED TO SERVICE YOUR REQUESTS AS PROMPTLY AS THE CUSTOMER SERVICE DEPARTMENT (1-800-851-1085).

PARTS REPLACEMENT ORDER FORM

** MODEL NO. _____ **			NAME: _____		
Parts Required	PART NO.	QTY.	COLOR	ADDRESS: _____	
				CITY: _____ PROVINCE/STATE: _____	
				POSTAL CODE/ZIP: _____ TELEPHONE: _____	
				PURCHASED FROM: _____	
				STORE ADDRESS: _____	
FOR PARTS REPLACEMENT PLEASE CONTACT CUSTOMER SERVICE DEPARTMENT. TELEPHONE NO. (1-800-851-1085)			DATE PURCHASED: _____		

**or Mail To: 3069 Wolfedale Road
Mississauga, Ontario L5C 1V9**